

your new

ROYAL

portable



your new ROYAL

portable combines precision

workmanship, found only on the finest standard typewriter, with sparkling new features that make it the most modern and durable portable typewriter in the world. It's truly a standard typewriter in portable size.

Royal's "Touch Control" permits you to tailor the sensitivity of the keys to your own individual touch. The Line Meter automatically tells you how many lines of typing space you have left when you near the bottom of a page. "Magic" Margin permits you to set margins instantly, easily and automatically. These features, as well as Visible Tab Set, Push Button Top, Automatic Paper Lock, greater paper capacity and many others, help you to type faster, better, with less error.

Read this booklet carefully. Its complete instructions on the use of Royal's convenience features will help you to get the most out of your new Portable Typewriter.



index

1. Inserting & Removing Paper
2. Line Spacing
3. Using the Scales
4. Carriage Spacing
5. Keyboard & Ribbon Controls
6. "Magic" Margin
7. Tabulating
8. Line Meter
9. "Touch Control"
10. Ribbon Changing
11. Care of Portable; Portable Case Carriage Centering Device
- 12.-13. Portable Feature Chart

inserting paper

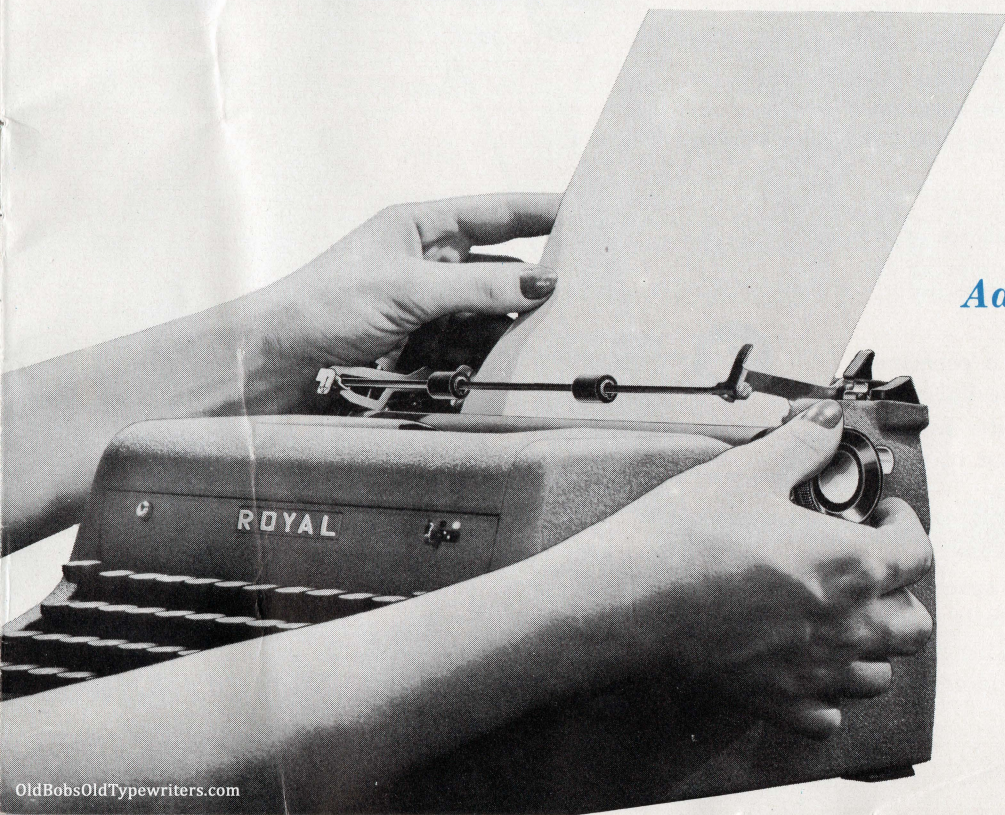

A. Pull forward Automatic Paper Lock and drop paper behind cylinder onto Royal's single wide rear feed roll which acts as a straight edge, guiding the left edge of paper against paper guide.

B. Turn either cylinder knob until paper comes up under the Automatic Paper Lock. The rollers on the Paper Lock should be spaced to divide the paper in thirds. Flip back the lock with the right thumb.

Adjusting and Removing Paper

If it is necessary to adjust the paper after it has been inserted into the machine, pull forward the Paper Lock and the Paper Release Lever located to the right of the Paper Lock Lever. Adjust the paper, then push back the Paper Lock and the Paper Release Lever. Remove paper by pulling forward these same two levers or by rolling it out by means of either cylinder knob.

line spacing

1 *Line Finder.* To change the line spacing to a fraction of a line temporarily, as when typing chemical or mathematical formulae (A^2+B^2 or H_2O), move the Line Finder forward and rotate the cylinder to the desired position. To return to the exact original spacing, move the Line Finder to its rearward position.

2 *Line Space Selector.* You have your choice of single, double or triple spacing between the lines by moving the Line Space Selector to the desired number.

3 *Variable Line Spacer.* To make a permanent change in the line spacing, press in the Variable Line Spacer button while rotating the Cylinder Knob. Locate the work exactly where you want it, then release the button. The spacing is now permanently changed to the new set-up.

4 *Line Space Lever.* Line spacing and carriage return are accomplished simultaneously with a single, brisk sweep of the left hand against the Line Space Lever. Royal's specially designed finger-piece brings increased comfort and ease to this operation.

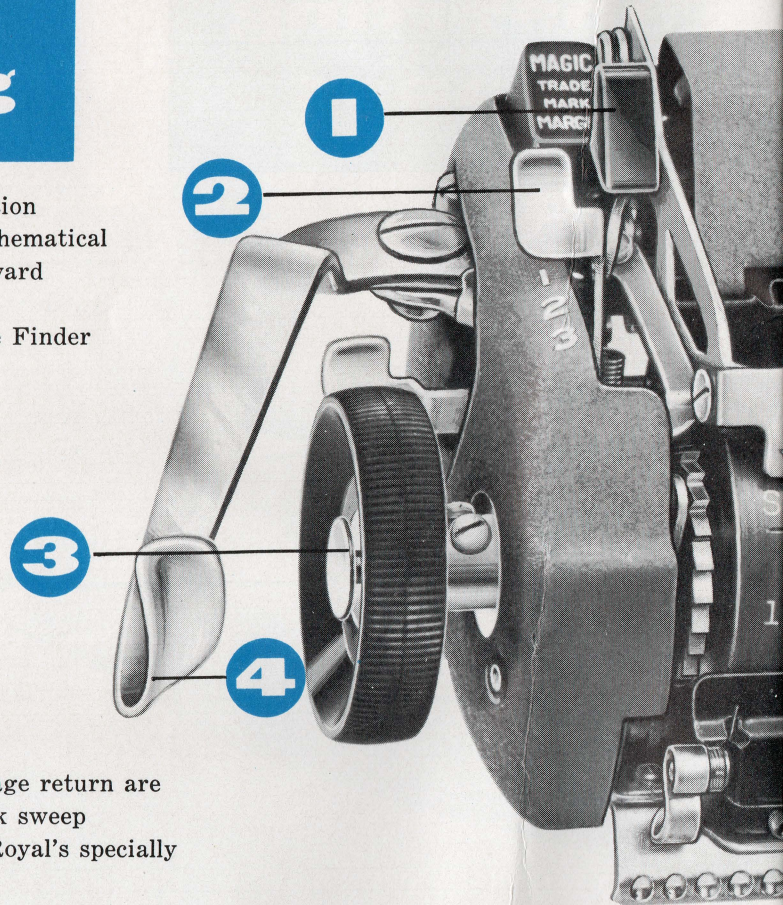

1 **The Paper Guide Scale.** The Paper Guide is usually set at zero. For positioning a series of cards or envelopes, the Paper Guide may be set to the right of zero.

The Tabulator Scale. The Tabulator Scale is a continuation of the Paper Guide Scale and can be seen by tilting back the Paper Table. This scale is used to set the tab stops which are located directly behind it.

2 **The Paper Lock Scale.** The Paper Lock Scale spans the cylinder and is completely visible at all times. Use this scale to compute measurements on the paper. To determine margins or tab settings used in the upper part of the page, simply raise the Paper Lock, hold the paper under the scales and make the readings.

3 **Card and Writing Line Scale.** This scale is used to align characters with work already on the page or card. The edge

of the scale denotes the base of the writing line. To write on cards or envelopes, raise the Disappearing Card Finger at the right end of this scale.

4 **The Cylinder Scale.** Use this scale to locate the carriage at a specific printing point, as in setting margins, finding the center of a page, and centering headings.

To find the center of a page, add the left and right scale readings of the paper and divide by two. For instance, if the left edge of the paper is set at 0, and the reading at the right edge is 84, the center is 42. Move the carriage until the figure 42 on the cylinder scale is located at the printing point, and your page is centered.

To center a heading, locate the center of the page as above. Then press the Back Space Key *once* for each *two* letters and spaces in the heading.

All Scales are synchronized and read from left to right.

using
the
scales

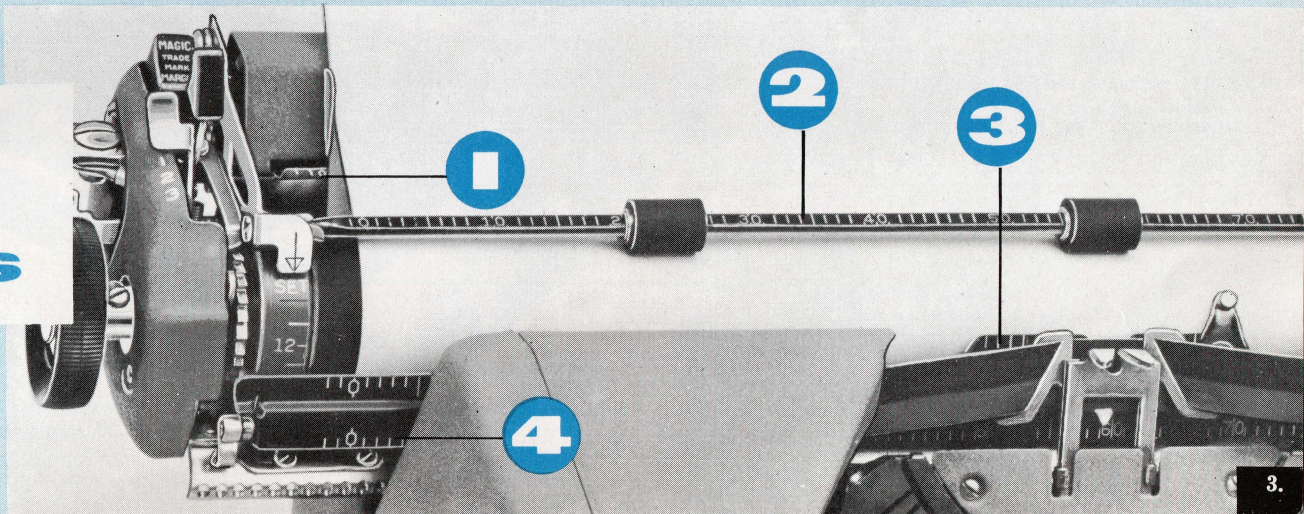

carriage spacing

Carriage Release

Levers. The carriage may be released and moved any number of spaces by holding in either the left or right Carriage Release Lever.

Back Space Key

The carriage may be moved back one space at a time by touching the Back Space Key.

Speed Spacer. Royal's new space bar is faster and easier to operate. The carriage can be moved ahead one space at a time by touching the Speed Spacer.

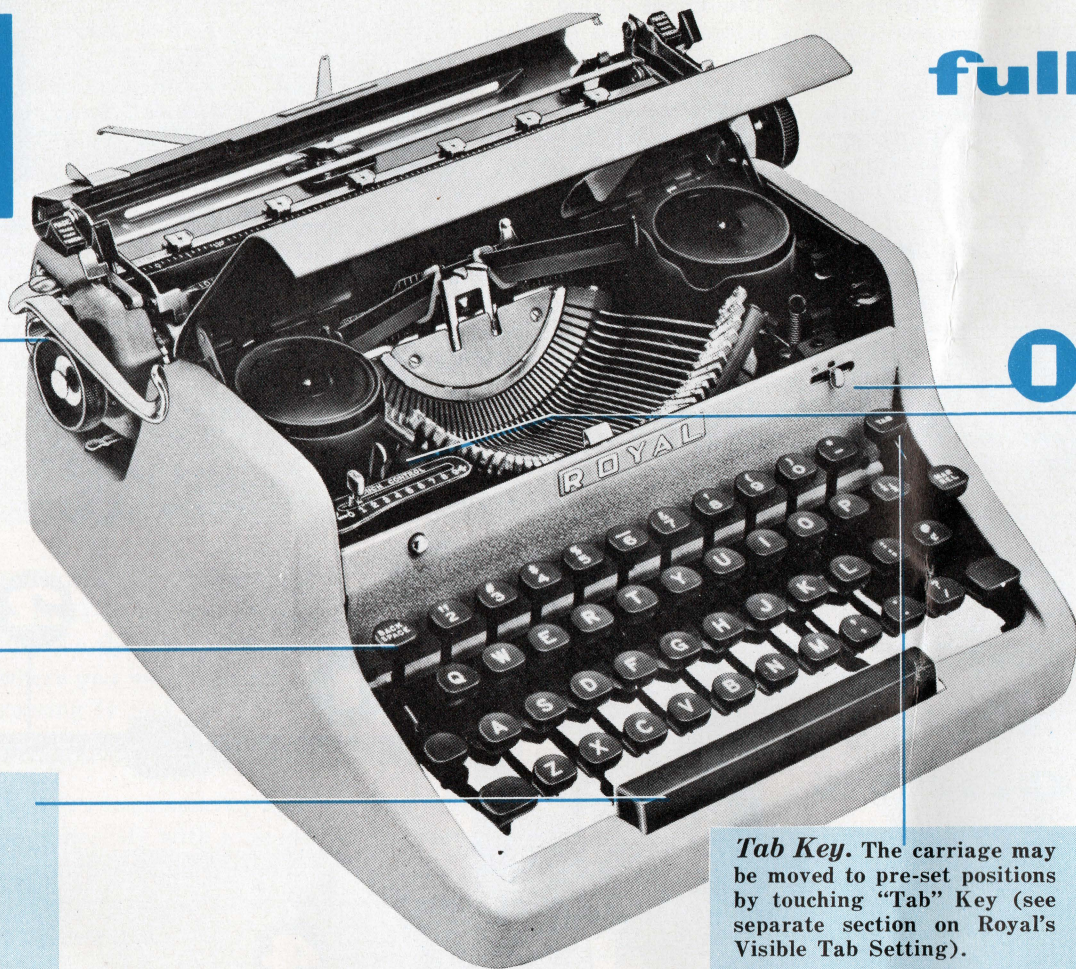

fully

Tab Key. The carriage may be moved to pre-set positions by touching "Tab" Key (see separate section on Royal's Visible Tab Setting).

standard keyboard

The Keyboard and controls on your Royal are like a standard office typewriter . . . designed for natural ease in typing. New plastic keys are Finger-Flow in shape. There's no obstructing semi-circle in front of the key to brush fingers or cause untidy work. Letters are inlaid right through the keys and cannot rub off; they stay clean, too, because they are exactly flush with key surface.

To type capitals or upper case characters press either Shift Key at the extreme ends of the lowest bank of letter keys, holding it down while you use the letter key.

To type capitals or upper case characters in sequence press the Shift Lock Key, just above the left Shift Key, which holds the segment in the upper case until you press either Shift Key.

Warning Bell and Margin Release. When in typing you approach the right margin, your warning bell will ring. After you have typed several more characters, the line lock will take effect, locking the type bars to prevent you from typing one character over another.

To type past the right margin line lock, or to type within your left hand margin, press the Margin Release Key.

ribbon color change and reverse

The Ribbon Color Change Lever (1) permits you to use either the upper or lower halves of the ribbon. To type using the lower, or red, half of a two-color ribbon, move the lever to the red dot. To use the upper, or black, half of the ribbon, move the lever to the black dot. To make the ribbon inoperative for stencil writing, move the lever to the white dot.

The ribbon reverses itself automatically when the end of the ribbon is reached. However, it may be reversed at any time by moving the Ribbon Reverse Lever (2) to its opposite position.

***When purchasing new ribbons,
be sure to get a ribbon made
expressly for the Royal Portable.
Ask for Roytype Ribbons by name.***



"magic" margin

"Magic" Margin allows you to set margins automatically without disturbing paper in machine. To set left margin, hold in the left carriage release lever and left "Magic" Margin button while moving carriage to point you wish your writing line to start—release, and it's set. To set the right margin, merely follow same procedure, using right carriage release lever and right "Magic" Margin button.

tabulating

Royal's Visible Tab stops are made instantly accessible by simply tilting back the Paper Table. These tab stops are used to mark off various indentations and to halt the carriage at these points. To set a tab stop, note the reading on the cylinder scale where you wish the carriage to halt, then press down on the tab stop and move it till the red line on it is aligned with the same reading on the Tabulator Scale. To tabulate—that is, to move automatically from one column or indentation to the next, hold down the Tab Key until the carriage halts.

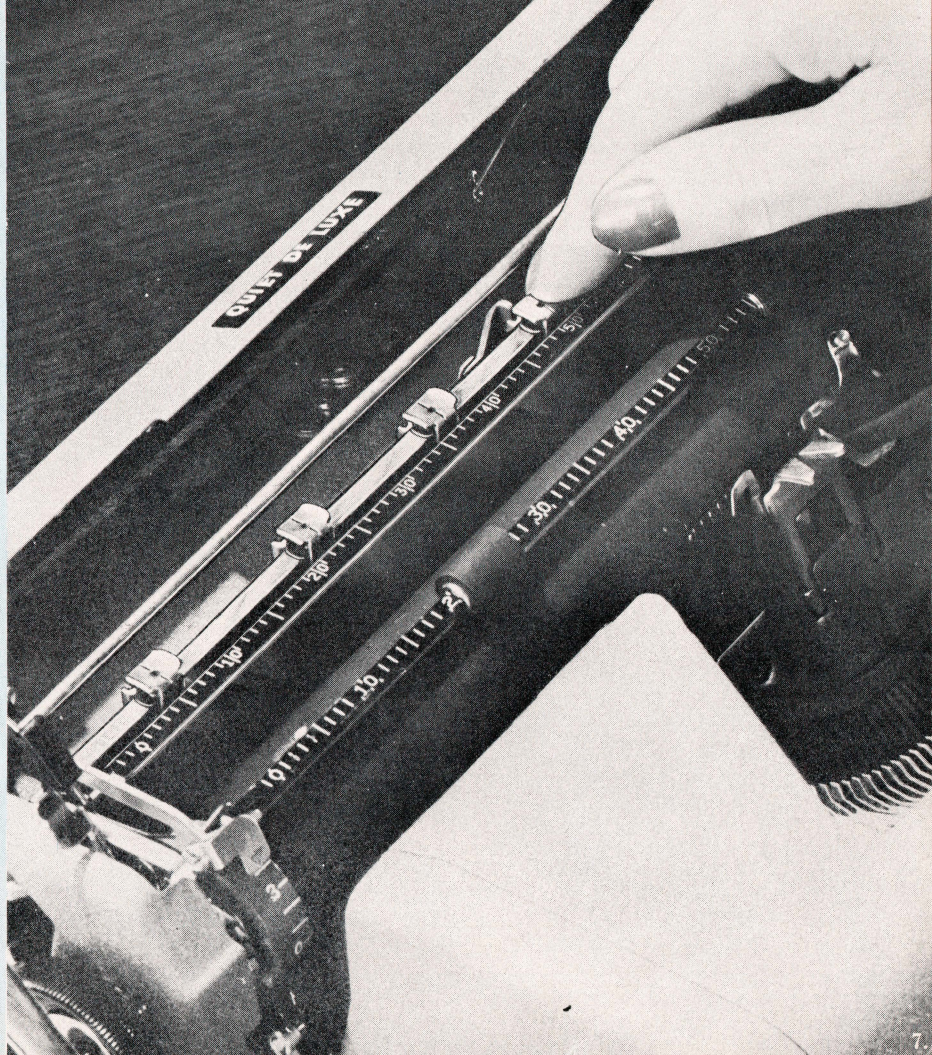

line meter

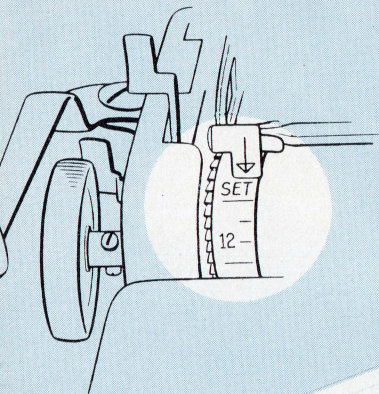

This amazing new device automatically tells you how many lines you have left when you are typing near the bottom of a page. Simply insert paper in regular manner and turn either cylinder knob until the red SET line on the Line Meter appears directly beneath the arrow. Then hold the Variable Line Spacer button all the way in while turning the right cylinder knob until the back edge of the paper is aligned with the two red dots on the Paper Support. (Be certain to raise the Paper Support to its uppermost position.) Release the Variable Line Spacer button, then turn the cylinder to the desired typing position. As you near the bottom of the page, the numbers on the Linemeter will automatically indicate exactly how many lines of typing space you have left.

If you type on a paper or card that is too short to be aligned with the red dots on the Paper Support, use the same directions as above, but align it with the red lines directly behind the cylinder instead of the red dots on the Paper Support.

This feature, made famous on Royal Office Typewriters, adjusts the sensitivity of the keys to your own touch. Move the "Touch Control" Lever toward the high numbers and the keys automatically adjust themselves for a firm or heavy touch. If you have a light touch move the lever to the low numbers.

**"touch
control"**



4 step ribbon change

1 Press Shift Lock Key and move Color Control lever to red dot. Then depress any two central keys at the same time so that the type bars stand up and the Ribbon Carrier is raised. Disengage the ribbon from the Ribbon Carrier.

2 Raise the Push Button Top and wind ribbon as far as possible on either spool. Slip the ribbon out of the small guides beside each ribbon cup. Lift off both spools, unhook and discard used ribbon from empty spool.

3 Hook the new ribbon to the empty spool and replace both spools on their hubs, making sure the ribbon travels from the back of each spool as shown in the illustration.

4 Feed ribbon through small guides and replace in Ribbon Carrier. Flick back the type bars and release the Shift Lock. Take up ribbon slack by turning either spool. Lower the Push Button Top and you are ready to type.



care of your royal portable

To increase typing satisfaction, follow these simple rules:

- From time to time, dust the outside and accessible parts with a brush or dry cloth.
- Clean the type frequently with the dry bristle brush furnished with your Royal Portable.
- Wipe the carriage rails and other nickel parts occasionally with a cloth moistened with a very little oil.
- Don't erase directly over the printing point. Move the carriage to either side, then erase.
- Keep your Portable covered when not in use.

Record your Royal Portable serial numbers on your bill of sale, this instruction book, or in some other safe place. You will find it by moving the carriage to the extreme right and looking down into the base of the portable. Your Royal Portable can always be identified by its serial number.

Carriage Centering Device—This feature enables you to center the carriage with the base of the typewriter to give an added safety measure when carrying your Royal Portable.

To engage the Carriage Centering Device: 1) move the carriage to the extreme right; 2) depress the Carriage Centering Lever; and 3) move the carriage back to the left until the Carriage Centering lock is engaged. This will center your carriage and lock it into position.

To disengage the Carriage Centering Device, raise the Carriage Centering Lever until the carriage is released. The carriage can then be set where desired.

royal portable case

Your Royal Portable comes in a highly-styled fiberglass carrying case that is lightweight and very durable. Clips inside the top of the case are designed to hold paper and envelopes.

If you like, use your Royal Portable in its case. Simply open the cover and you are ready to type. Or, remove the top of the case by holding the Hinge Lock toward you and slide off the top to the right.

For the quietest typing of all, remove the Portable from the case. To do this release the two base clamps and lift the Portable outward from the base of the case. To replace it in the case, angle the back of the portable onto the base catch, then set the front of the machine on the feet pins and re-engage the clamps.

feature

1. "Magic" Margin Left
2. Paper Guide
3. Paper Guide Scale
4. Paper Table
5. Automatic Paper Lock
6. Paper Lock Rolls
7. Writing Line Scale
8. Adjustable Paper Support
9. Carriage Position Indicator
10. Ribbon Carrier
11. Disappearing Card Finger
12. Cylinder Scale
13. Visible Tab Stops
14. Tabulator Scale
15. "Magic" Margin Right
16. Paper Release Lever
17. Right Carriage Release
18. Cylinder
19. Right Cylinder Knob
20. Ribbon Color Change Lever
21. Tabular Key
22. Margin Release Key
23. Right Shift Key
24. Speed Spacer
25. Left Shift Key
26. Shift Lock Key
27. Fully Standard Keyboard
28. Back Space Key
29. Push Button Top
30. "Touch Control"
31. Ribbon Reverse
32. Carriage Centering Device
33. Line Space Lever
34. Left Cylinder Knob
35. Variable Spacer
36. Line Meter
37. Left Carriage Release
38. Line Space Selector
39. Line Finder

chart

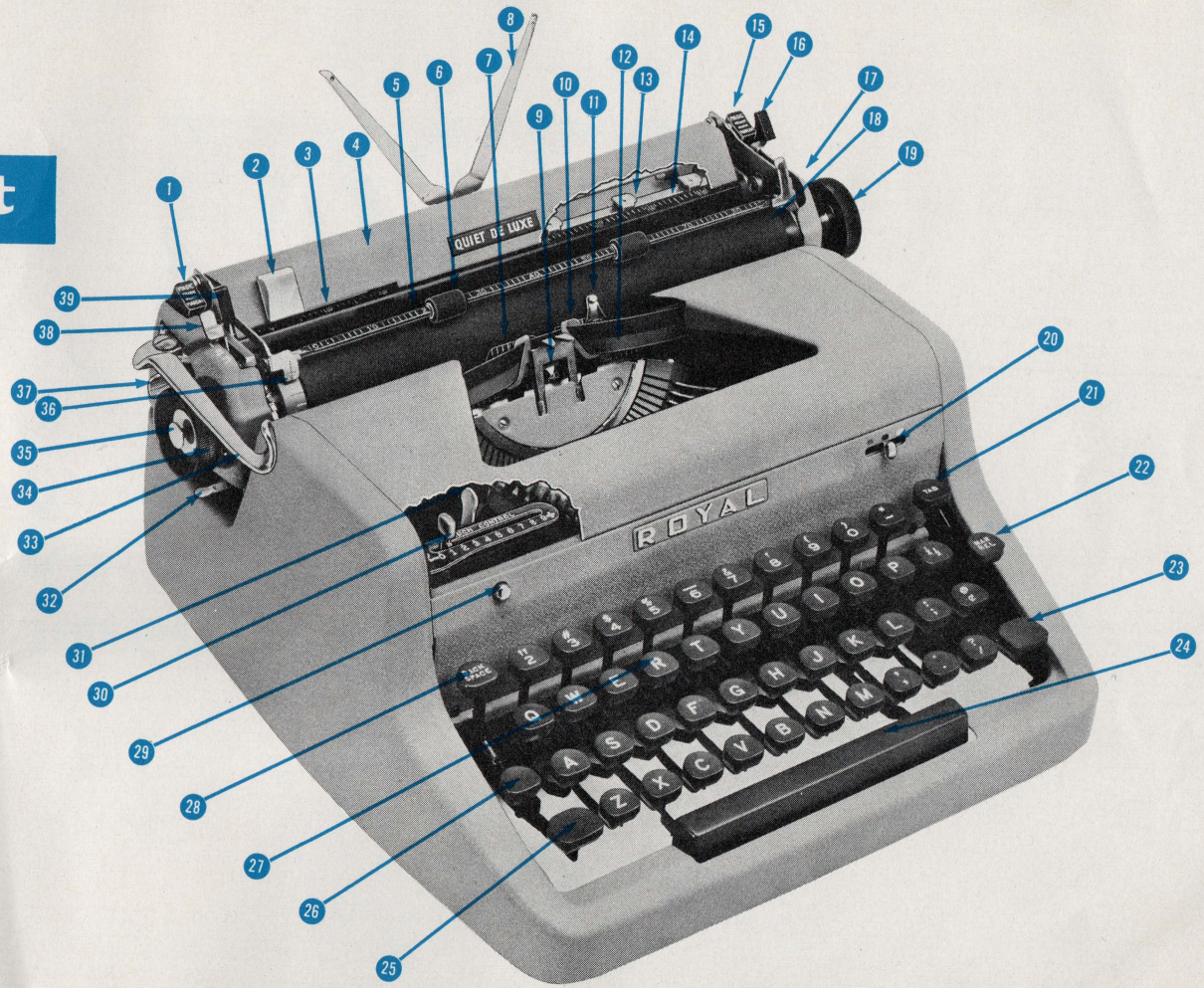



ROYAL

Portable Department

**royal
typewriter
company**

DIVISION OF ROYAL McBEE CORP.

*2 Park Avenue
New York 16, N. Y.*