

---

*Rheinmetall* 

PORTABLE  
TYPEWRITER

*Handwritten scribbles in blue ink, possibly initials or a signature.*

Directions for Use

---



Direktions for Use

RHEINMETALL  
PORTABLE  
TYPEWRITER



Modell KsT

*Rheinmetall*



Sömmerda / Thür.



With regard to the following operation instructions for the Rheinmetall-Portable Typewriter, we suggest folding out the main illustration leaf to the right, in order to render a comfortable survey while checking up the parts stated in the text.



# LIST OF CONTENTS

	Page
Setting up the typewriter . . . . .	4
How to take off the cover . . . . .	4
How to insert the ribbon . . . . .	5
Ribbon Arrangement . . . . .	6
How to insert the paper . . . . .	6
Margin Adjustment . . . . .	7
Twisted Type Bar Disentangling Device . . . . .	8
Line Spacing . . . . .	8
Platen Release . . . . .	8
Shift Keys . . . . .	9
Back Spacer . . . . .	9
Spacer . . . . .	10
Dead Key . . . . .	10
Tabulator . . . . .	10
Touch Control . . . . .	12
How to take out the carriage . . . . .	13
Removal of Type Bars . . . . .	13
Practical Hints for Maintenance . . . . .	13
Designation of Typewriter Parts . . . . .	15



### Setting up the Typewriter

After removal of the locked case-cover and unlocking of typewriter carriage by setting lever 28 backward (fig. 5), the machine is ready for action.

Has the machine to be detached from the baseboard, e. g. for individual adjustment of key-stroke, the transport safety screws 33 (fig. 5 and 9) provided at either side below the machine, must be screwed out after loosening the check nuts. Subsequently the typewriter is lifted off from the baseboard on which it is held by two ball pins.

For placing the typewriter on back to the baseboard, proceed in reversed manner and watch that the safety screws are tightened but **slightly**.

Before closing the typewriter with the case-cover take notice that the coloured marking upon the line indicator 15 stands precisely below the line — of different colour — of the paper bail 7; then carriage lever 28 is set forward, whereby the carriage is locked.

### How to Take Off the Cover

In order to insert the ribbon or to take out and clean the type-bars, it is necessary first to remove cover 34 protecting the ribbon guide and type

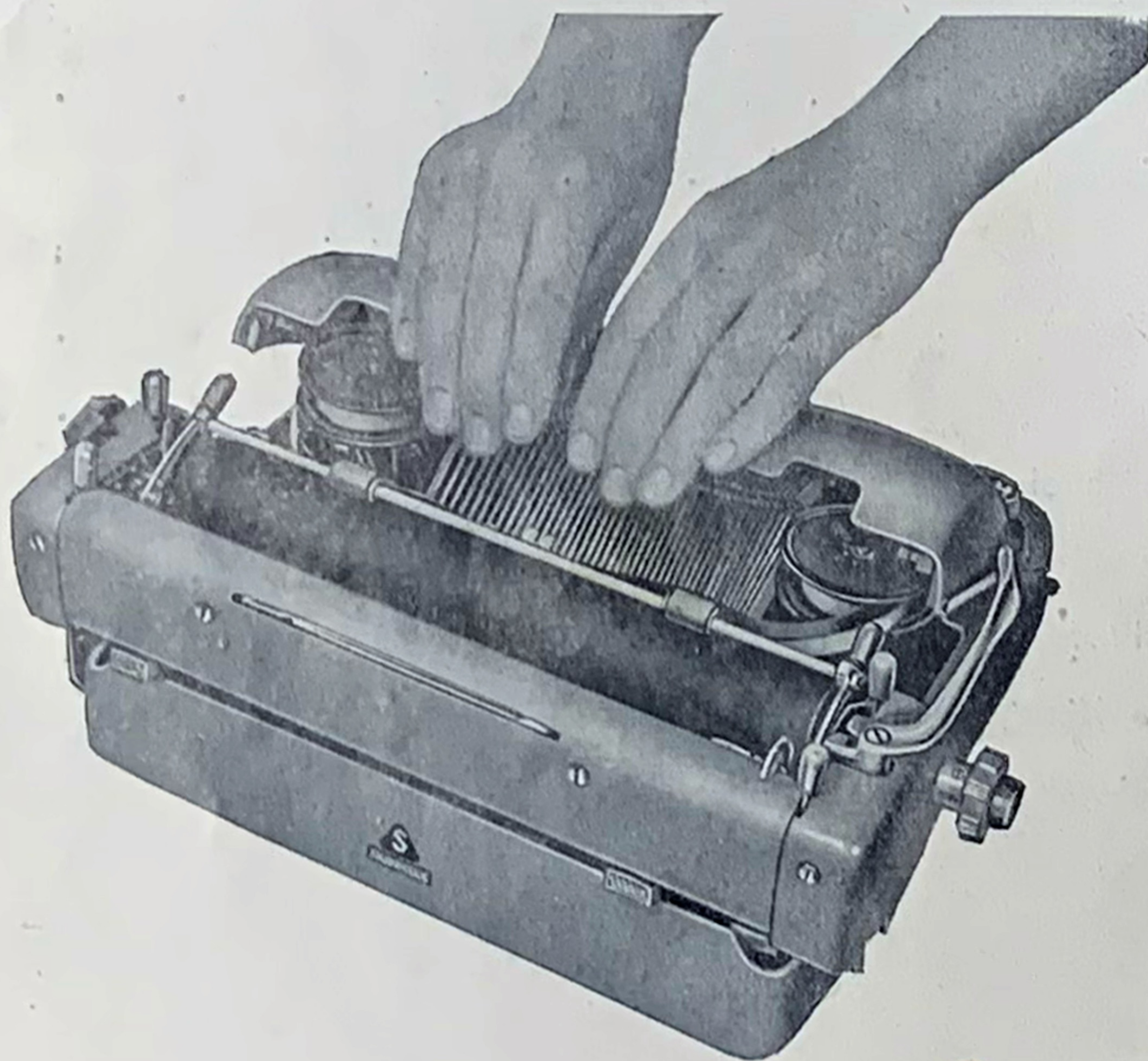

fig. 1



bars. After the carriage has been moved out to the left side by pressing the carriage release lever 10, the cover should be seized with two hands (fig. 1), pulled upward into the position shown in the illustration, and lifted out.

The cover can be placed back by holding it in the same oblique position, with its front edge supported on the frame, and pressing its rear portion downward until it snaps into position.

### How to Insert the Ribbon

The ribbon spools should be inserted so that the blue or black part of a two-coloured ribbon is on top and the ribbon is fed from the spools to the outside (fig. 2).

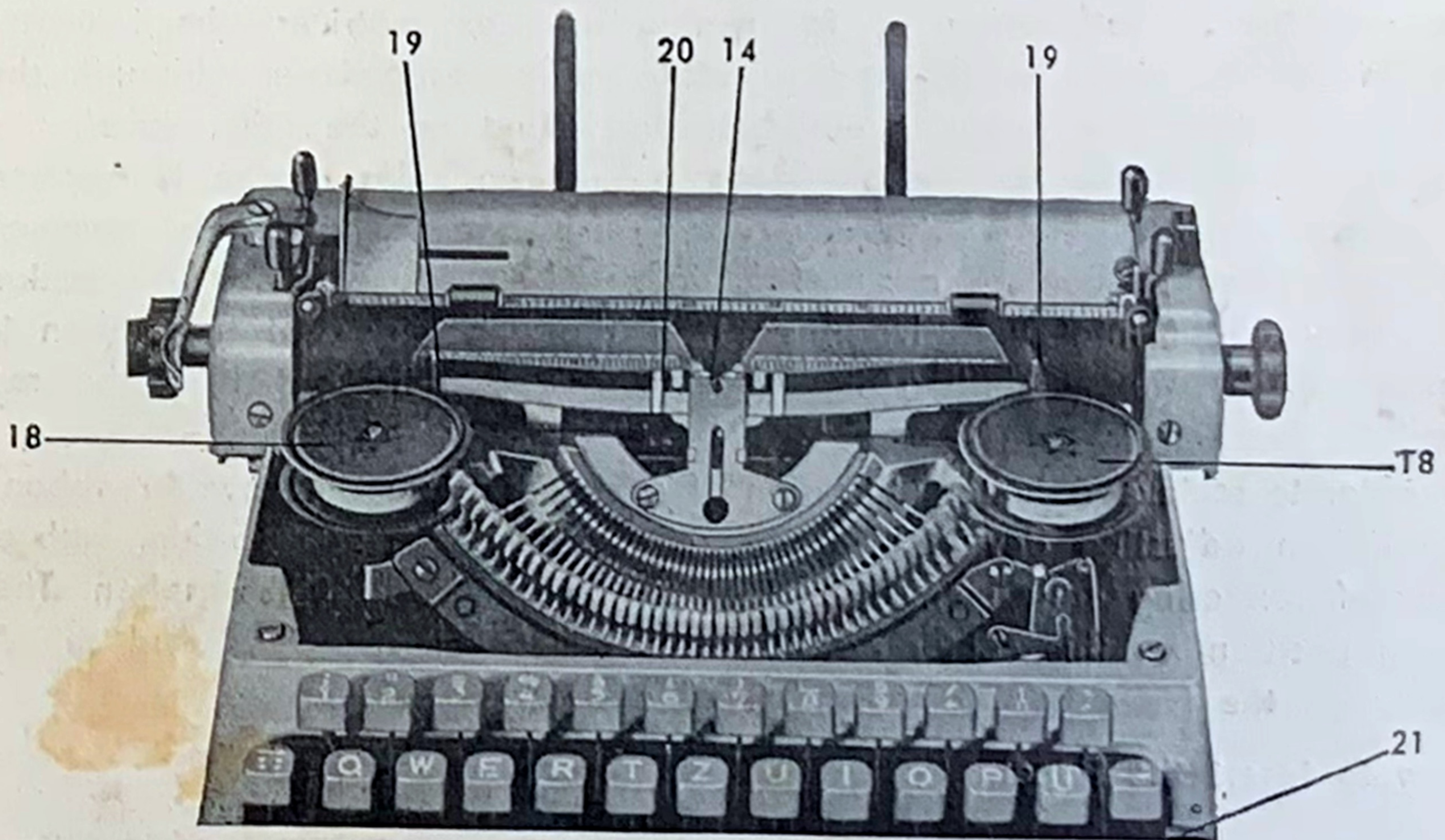

fig. 2

The ribbon is guided in ribbon reverse levers 19 and is held in the ribbon vibrator as shown in the sketch (fig. 3).

Spools and ribbons are standard sizes. The width of the ribbon is 13 mm.



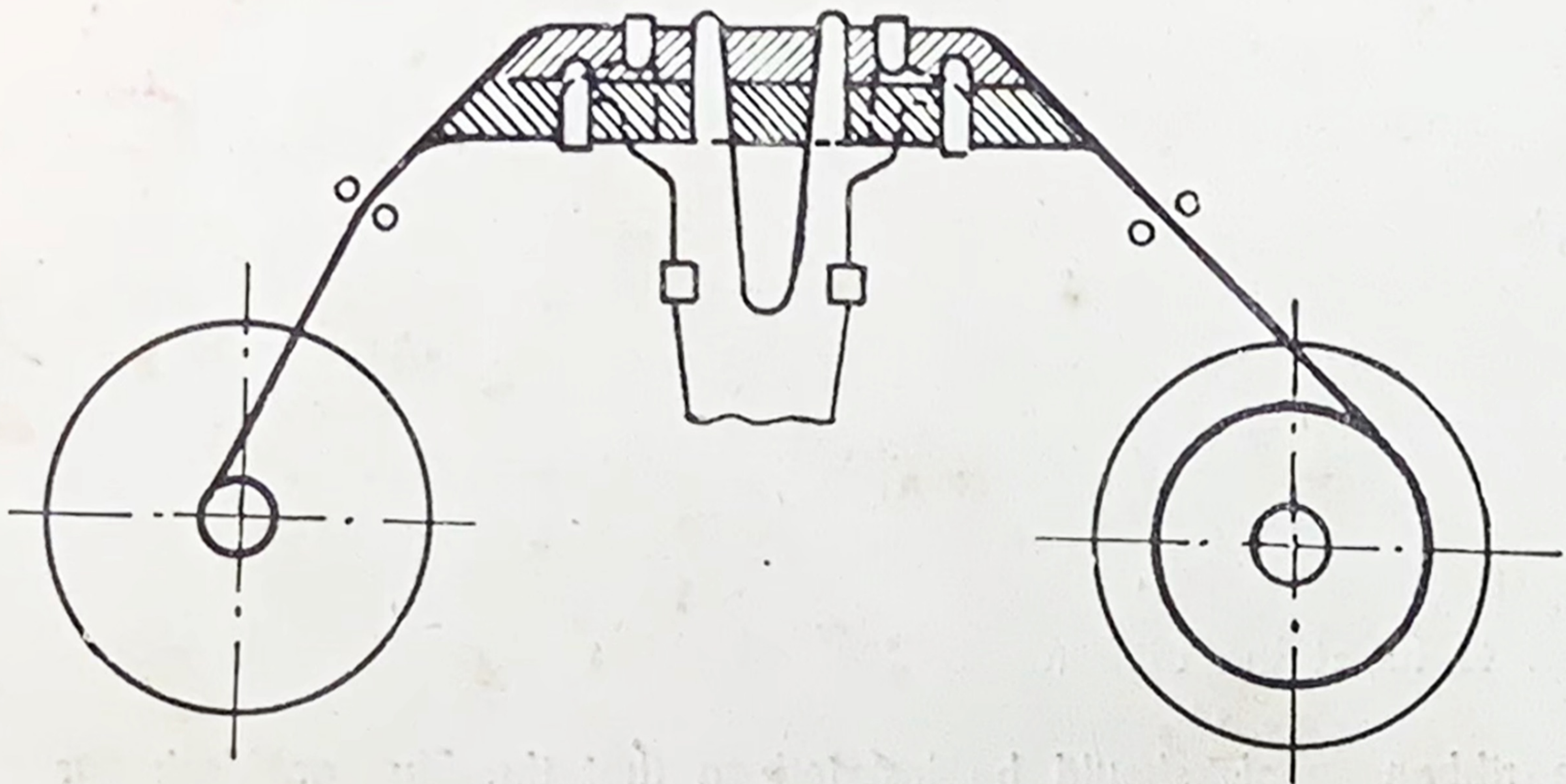

fig. 3

### Ribbon Arrangement

For ordinary writing, the ribbon position indicator 21 should stand opposite the blue mark. If the red portion of the ribbon is to be used, or the ribbon be switched off altogether as for writing on wax matrices, the indicator should be set either to the red or white mark, respectively. Although the ribbon fed from one spool is automatically wound on the other spool, two ribbon reverse knobs 20 are provided on the two sides of the type-writer, by operation of which the travelling direction of the ribbon can be reversed at any desired moment. If a singlecoloured ribbon is used, its lower section can be brought into operative position if the upper part of the ribbon is consumed, by simply shifting the ribbon position indicator 21 to the red mark.

In order to achieve a better utilization of a single coloured typewriter ribbon, the ribbon adjusting device incorporates a special center stop-deg, with a view of rendering convenient usage of the center part of the ribbon. The fixing position for this center adjustment lies between the „red“ and „blue“ marks on the typewriter frame and is of a different colour.

### How to Insert the Paper

Lay the paper against the lateral guide (6) (fig. 9) and insert the sheet between the platen and paper table. Turn the platen turning knobs 11, or one of them, to move the sheet into writing position. Lift paper holding scale 7 and introduce the sheet between the latter and the platen. Then push the paper holding scale down, so that its feed rollers press the sheet firmly against the platen. In order to adjust sheets introduced obliquely or to set them to the desired line, pull paper release lever 9 forward, scale lifter 8 backward, and adjust the sheet as desired. When scale lifter 8 is



pulled forward, the two feed rollers of paper holding scale 7 make it possible to type letters, envelopes, postcards, index cards, and the like down to the lower edge of the sheet.

When making a larger number of copies or when using copying ribbons, it is advisable to push paper lifter 8 backward in order to prevent slurring by the pressure of the feed rollers on paper holding scale 7.

### Margin Adjustment

Margin stops 30 and 31 (fig. 4) are arranged on the rear side of the typewriter. They can be moved to the two sides to limit the travel of the carriage, fixing the margin of the text. In order to mark the beginning or the end of a line, the carriage should be moved into the corresponding position and the pertinent margin stop shifted laterally as far as it will go, pressing its button; thus the left margin stop 30 will indicate the beginning and the right margin stop 31 the end of a line. If the carriage is to travel beyond the left margin stop, it is only necessary to depress margin release key 26 and to move the carriage into the desired position. The margin adjustment on the right will also operate a bell signal, which will sound 8 letters ahead

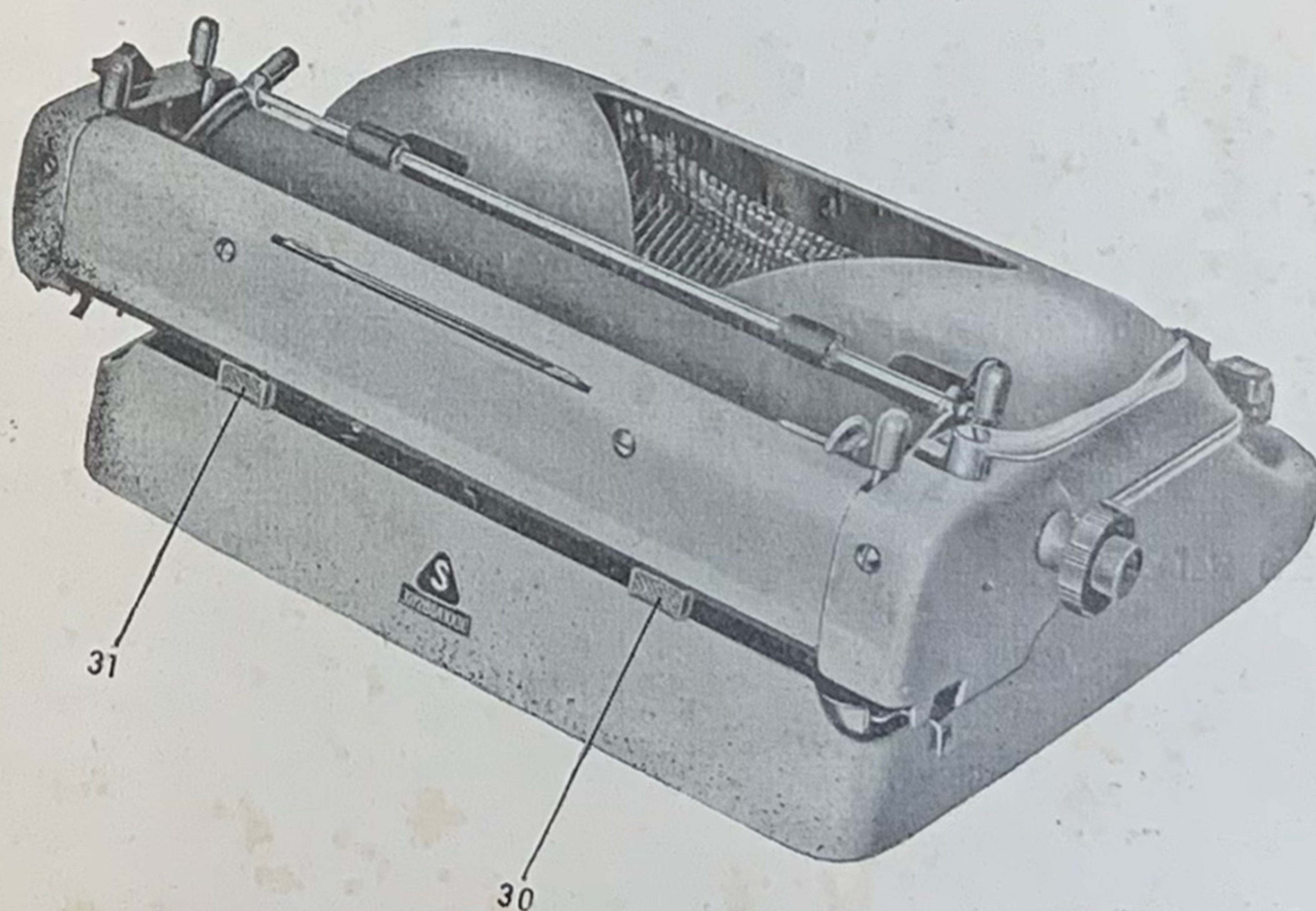



fig. 4



of the key ratchet before the end of the line. When writing beyond the original margin stop becomes necessary, just press down ratchet release key 26 and continue writing.

### Twisted Type Bar Disentangling Device

As a special feature, the Rheinmetall Portable Typewriter employs a disentangling device which enables to free type bars which became twisted before the type guide, either by uneven key stroke or by striking two keys simultaneously.

This device is operated by the margin release key. A short strong stroke on the margin release key 26  is sufficient to free the twisted type bars which drop back to their resting position. Thus, unpleasant soiling of fingers, usually linked with manual interference, is abolished herewith.

### Line Spacing

The spacing of the lines is effected by means of line spacing lever 1. By actuating this lever, the carriage can be moved to the right into its initial position, while the platen is simultaneously turned on by the desired line space. The width of space is adjusted by means of line space adjusting lever 2, which can be set according to a scale arranged on its left side.

### Platen Release

In order to be able to type on printed lines, or between lines, press down platen release knob 3 arranged on the platen turning knob on the left side. The platen can then be turned freely to any desired line. Use line finder 15 (fig. 9) as a rule.

By giving the depressed platen release knob a slight backward turn, the platen is permanently released from its ratchet, until the knob is turned back again.



## Shift Keys

In order to use capitals and some other types, one of the two shift keys 24 has to be depressed. For writing capitals permanently, the shift keys can be fixed by pressing down shift lock 25. This key is released again by slightly touching the left shift key 24.

## Back Spacer

Back spacer 22, if depressed, retracts the carriage by the space of one type. With the aid of this key, the correction of printing mistakes is greatly facilitated.

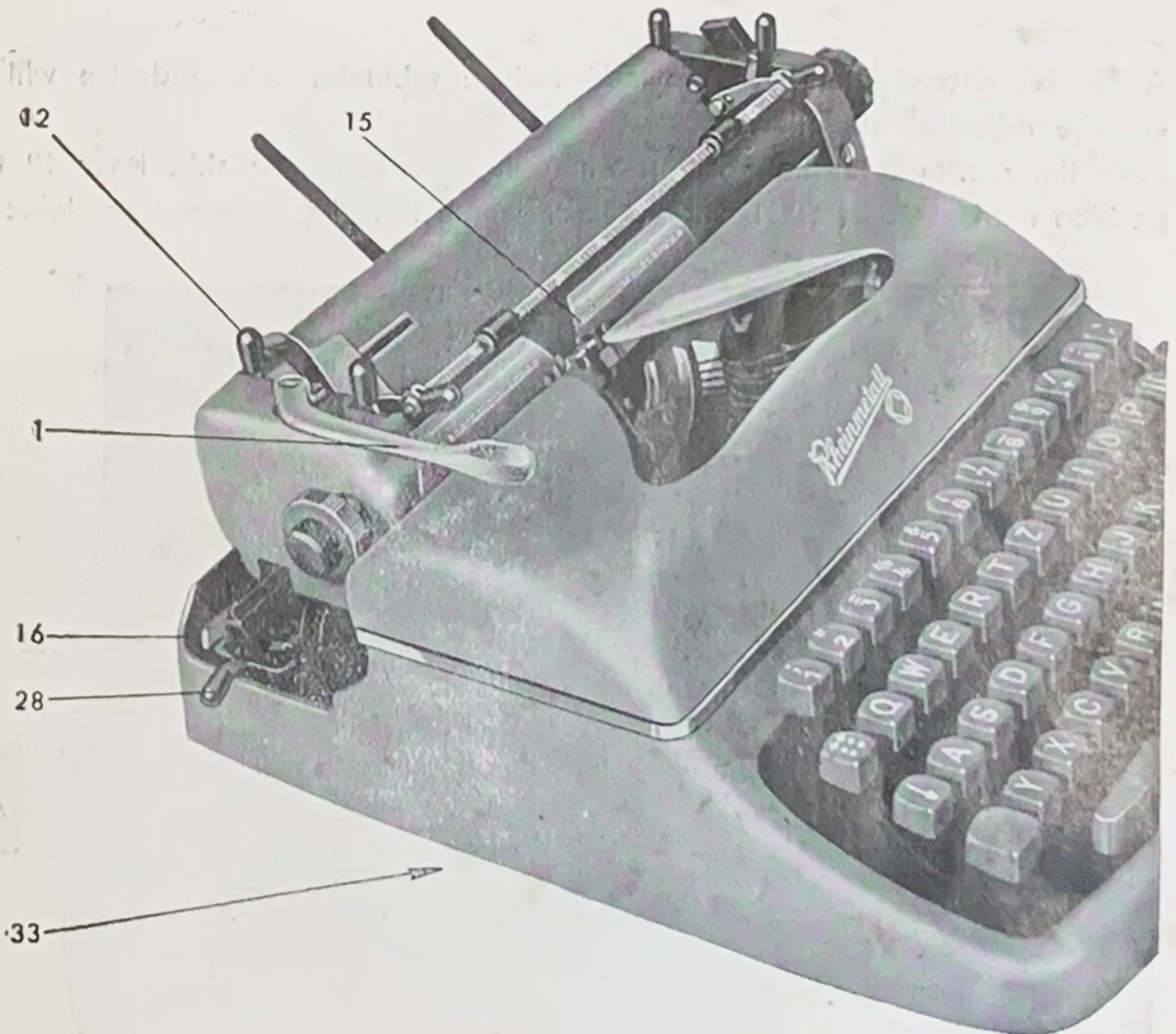

fig. 5



### Spacer

Spacer 27 is used to produce a space between the individual words. If words have to be written in spaced types, the space bar has to be depressed after each letter.

### Dead Key

For writing with accents in foreign languages dead key 29 (fig. 9) is incorporated. When the key is depressed, the carriage does not travel forward, but will remain in its position. If a letter is to be written with an accent on it, the accent should be typed first and then the letter. To put the accent  $\wedge$ , the upper and lower type on the dead key should be printed in succession.

### Tabulator

All portable typewriters are provided with a tabulator setting device which can be adjusted as follows:

Push the carriage to the position where it is to stop and shift lever 12 to position marked "S" (set). If such an adjustment is to be corrected or cleared,

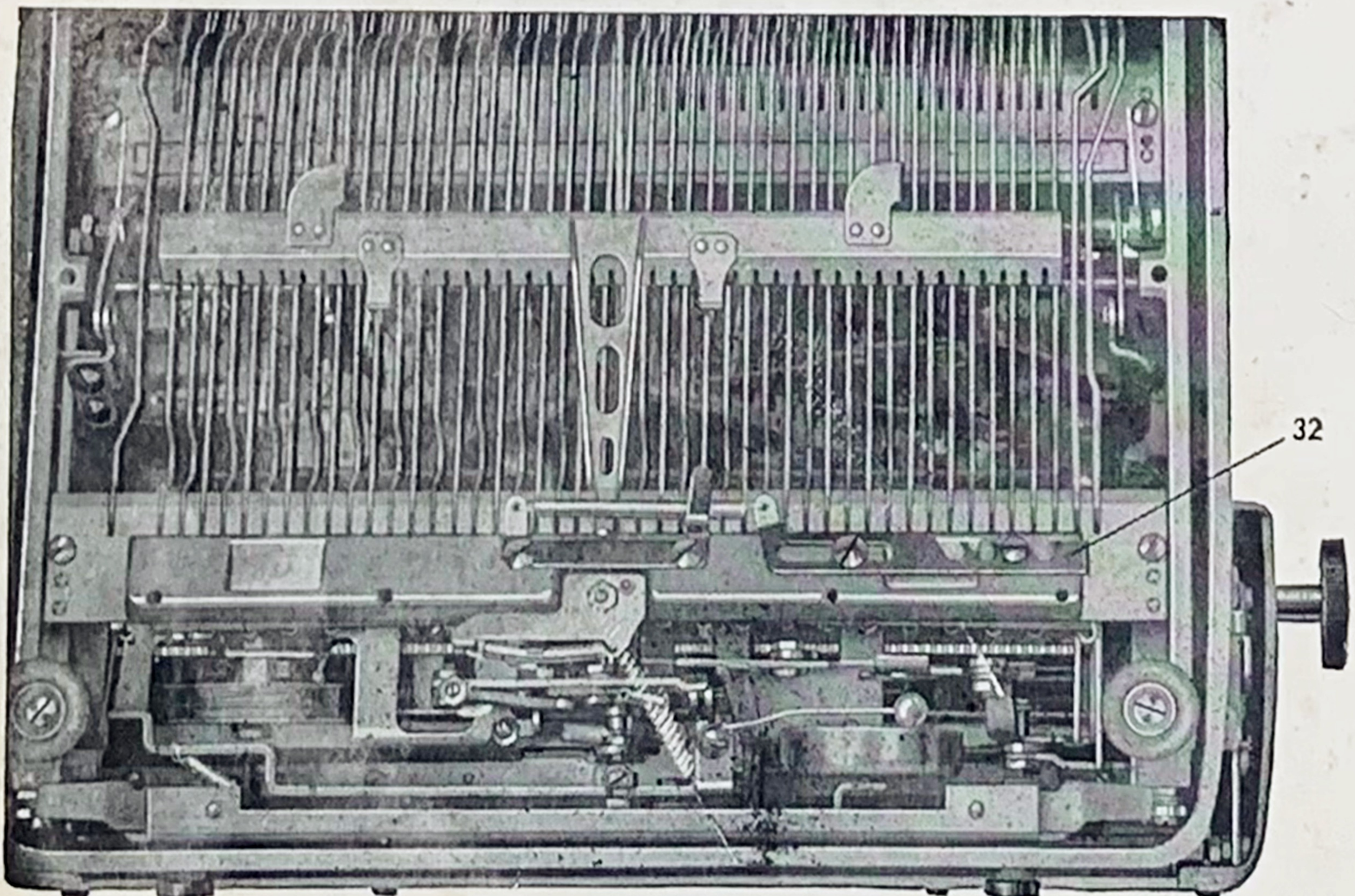

fig. 6



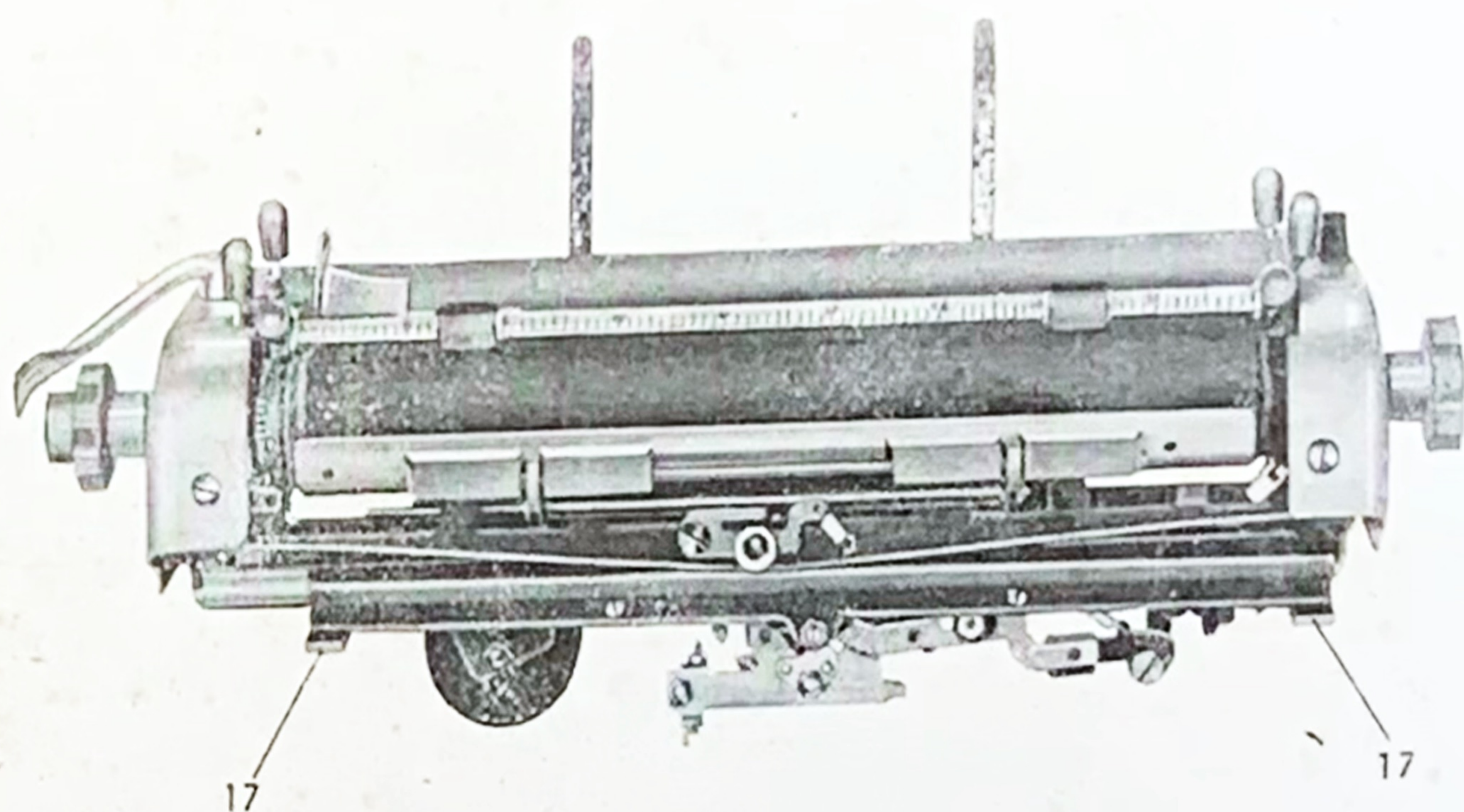

fig. 7



retract lever 12 to "L" (clear), after the carriage has been pushed to the corresponding position. In order to clear a tabulator setting altogether, the carriage should be pushed out to one side completely and then to the opposite side, while simultaneously pulling lever 12 forward to "L" until it engages the side stop.

When the necessary adjustments have been made, the columns of a printed form can be filled by simply depressing tabulator key 23, whereby the carriage jumps automatically into the positions, to which the tabulator had been previously set in accordance with the above directions.

### Touch Control

The touch control device which is mounted on the base of the typewriter (fig. 6) enables a variation of touch control in four steps.

This is achieved by disengagement and shifting of slide 32, which is located on the base of the typewriter and by re-engaging of same in one of the four notches, whereby the extreme left position of the slide renders a soft touch and the extreme right position a hard touch.

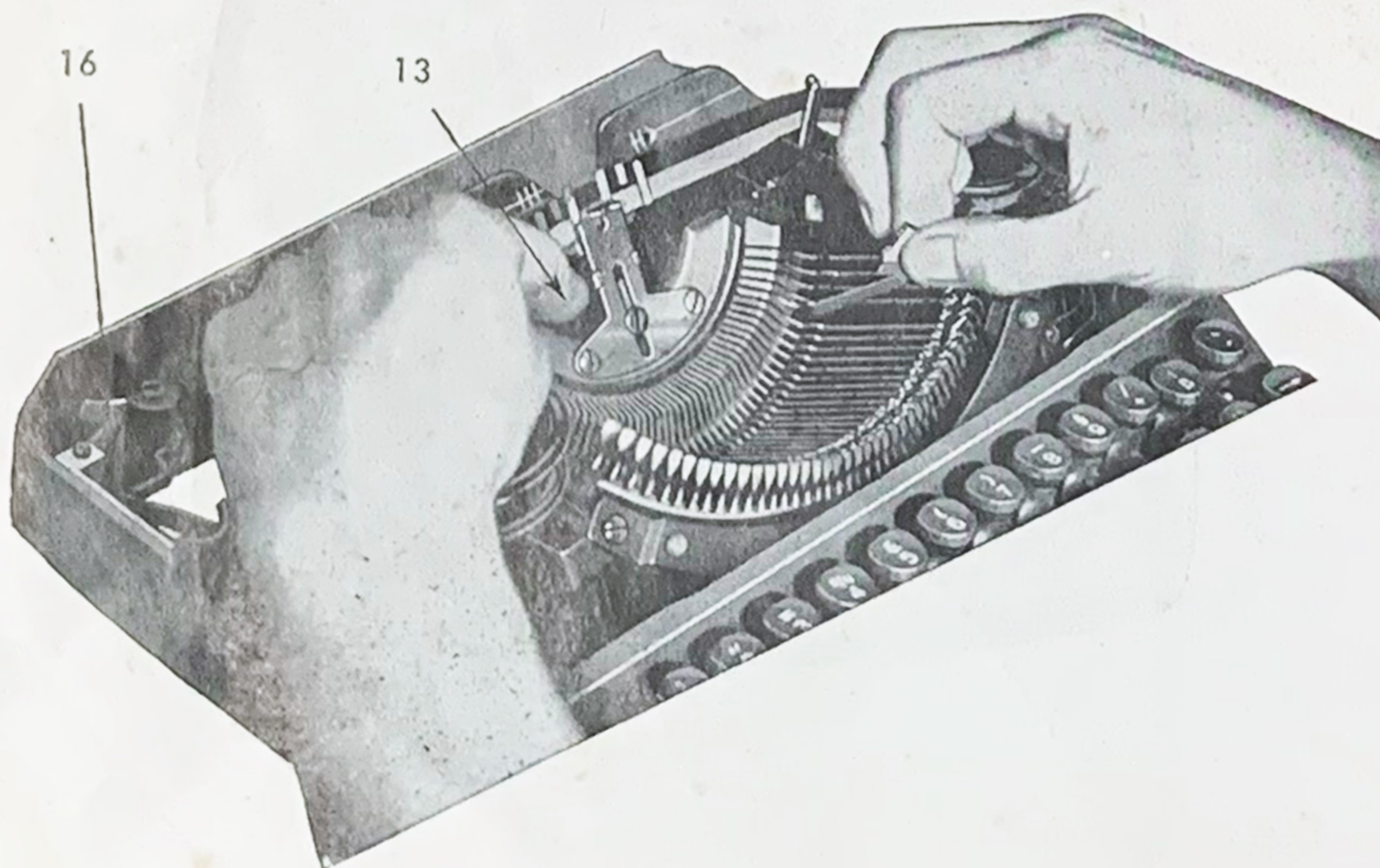

fig. 8



## How to Take Out the Carriage

The entire carriage can be easily removed after turning back both the carriage locks 16 (fig. 8) under the rear side of the typewriter casing (fig. 7).

While pressing down carriage release key 10, push the carriage to the left and right, thereby releasing the carriage locks 16. When replacing the carriage proceed in the opposite manner. Care has to be taken that the holding rails 17 (fig. 7) are brought forward below the holding screws and watch that the guide pins will engage the provided bore holes. One after another, the two carriage locking hooks 16 are then snapped over their fittings. Although removal and replacement of the carriage involves no difficulties, removal of same is not advisable unless there is a reason to do so.

## Removal of Type Bars

In order to remove the type bars from the segment e. g., for cleaning their bearing surfaces, the carriage has to be lifted out of the machine according to the directions given above. One finger of the left hand then depresses type bar release lever 13 (fig. 8), while the right hand seizes the type bar to be removed.

The latter is then pulled slightly forward and out of the slot in the segment, and unhooked from the tension hook. To place the bar back, proceed in an opposite sense, depressing the key actuating the type bar concerned. The carriage can then be placed back in the manner described above.

## Practical Hints for Maintenance

The types of the typewriter, when dirty, should be brushed thoroughly with a suitable type brush. Never use a needle or a pen to scratch the types out. If a type bar does not return properly, it should be removed as described in the previous paragraph, cleaned at its bearing surfaces, and placed back in position.

Regular cleaning of the typewriter will add to its life and assures flawless operation free from disturbances. As all parts of the typewriter are readily accessible, they are easily to be cleaned. Care should be taken, however,



that the springs within the mechanism are not bent. When the typewriter is not used, it is advisable to push the paper release lever 9 back so that the small rubber rollers do not permanently press against the platen. If the latter and the paper guide rollers have become unclean or smooth in the course of time, they should be rubbed with some spirit, but not be dried subsequently. Benzene should be used in no case as it destroys the rubber rollers.

Before the typewriter is oiled, all oiling spots should be freed from residues of old oil. It will be useful from time to time to oil the sliding parts of the shifting device and of the carriage transport, as well as the traction wires where they engage the type bars and intermediate levers. The ribbon vibrator need not be oiled. The segment slots should be kept clean of paper dust which would otherwise impair the free play of the levers.

For cleaning the machine's enamel finish or that of the keyboard, resp. removal of stains, e. g. from blue Ormig colour, a mixture of test-gasoline and acid-free oil, at a ratio of 2 : 1, proved suitable especially with wrinkly lacquer.

When this agent should not suffice with dull resp. high polish lacquer, it is advisable to use one of the usual motor car polishing pastes, applied with Nitro lacquer.









# RHEINMETALL-PRODUCTS

of top quality and precision

RHEINMETALLRHEINMETALLRHEINMETALLRHEINMETALLRHEI  
RHEINMETALLRHEINMETALLRHEINMETALLRHEINMETALLRHEI  
RHEINMETALLRHEINMETALLRHEINMETALLRHEINMETALLRHEI  
RHEINMETALLRHEINMETALLRHEINMETALLRHEINMETALLRHEI

## Portable Typewriters

RHEINMETALLRHEINMETALLRHEINMETALLRHEINMETALLRHEI  
RHEINMETALLRHEINMETALLRHEINMETALLRHEINMETALLRHEI  
RHEINMETALLRHEINMETALLRHEINMETALLRHEINMETALLRHEI  
RHEINMETALLRHEINMETALLRHEINMETALLRHEINMETALLRHEI

## Standard Size Typewriters

RHEINMETALLRHEINMETALLRHEINMETALLRHEINMETALLRHEI  
RHEINMETALLRHEINMETALLRHEINMETALLRHEINMETALLRHEI  
RHEINMETALLRHEINMETALLRHEINMETALLRHEINMETALLRHEI  
RHEINMETALLRHEINMETALLRHEINMETALLRHEINMETALLRHEI

## Adding Machines

RHEINMETALLRHEINMETALLRHEINMETALLRHEINMETALLRHEI  
RHEINMETALLRHEINMETALLRHEINMETALLRHEINMETALLRHEI  
RHEINMETALLRHEINMETALLRHEINMETALLRHEINMETALLRHEI  
RHEINMETALLRHEINMETALLRHEINMETALLRHEINMETALLRHEI

## Calculating Machines

RHEINMETALLRHEINMETALLRHEINMETALLRHEINMETALLRHEI  
RHEINMETALLRHEINMETALLRHEINMETALLRHEINMETALLRHEI  
RHEINMETALLRHEINMETALLRHEINMETALLRHEINMETALLRHEI  
RHEINMETALLRHEINMETALLRHEINMETALLRHEINMETALLRHEI

## Billing Machines

RHEINMETALLRHEINMETALLRHEINMETALLRHEINMETALLRHEI  
RHEINMETALLRHEINMETALLRHEINMETALLRHEINMETALLRHEI  
RHEINMETALLRHEINMETALLRHEINMETALLRHEINMETALLRHEI  
RHEINMETALLRHEINMETALLRHEINMETALLRHEINMETALLRHEI

## Accounting Machines

The Rheinmetall production line offers the right machine for every working place