

GOV DOC
D 101.11:
10-601

TM 10-601

DEPARTMENT OF THE ARMY TECHNICAL MANUAL

FEB 5 1955

UNDERWOOD TYPEWRITER MAINTENANCE AND REPAIR



ROUSE HUBBARD

DEPARTMENT OF THE ARMY • September 1955

UNDERWOOD TYPEWRITER MAINTENANCE AND REPAIR

	<i>Paragraphs</i>	<i>Page</i>
CHAPTER 1. INTRODUCTION.....	1, 2	2
2. MAINTENANCE AND REPAIR		
Section I. Description, maintenance and repair tools.....	3, 4	3
II. Cover plates.....	5-12	3-5
III. Main carriage mechanism.....	13, 14	5-6
IV. Mainspring mechanism.....	15, 16	6-8
V. Line space mechanism.....	17, 18	8-9
VI. Variable mechanism.....	19, 20	10-11
VII. Paper feed mechanism.....	21, 22	11-13
VIII. Escapement mechanism.....	23-29	13-21
IX. Backspace mechanism.....	30-33	21-23
X. Ribbon feed mechanism.....	34-39	23-26
XI. Ribbon reverse.....	40-42	26-27
XII. Ribbon cover mechanism.....	43-45	27-30
XIII. Margin mechanism.....	46-48	30-34
XIV. Tabulator mechanism.....	49-53	34-38
XV. Subcarriage and shift assembly.....	54-56	38-43
XVI. Cylinder scale frame assembly.....	57-59	44-45
XVII. Segment assembly.....	60, 61	46
XVIII. Alinement.....	62-64	47-48
XIX. Disassembly and reassembly.....	65-73	49-60
XX. Troubleshooting.....	74, 75	60-64
XXI. Cleaning and lubrication.....	76, 77	65
CHAPTER 3. SHIPMENT, LIMITED STORAGE, AND DEMOLITION TO PREVENT ENEMY USE..	78, 79	66
APPENDIX REFERENCES.....		67
INDEX.....		68

CHAPTER I

INTRODUCTION

1. Scope

This manual contains information necessary for the maintenance and repair of Underwood standard typewriters, serially numbered from 4,280,000 to 5,800,000. It deals with only those phases of operation that are necessary to enable the repairman of Underwood standard typewriters to best perform maintenance, adjustment, and repair functions. Although the individual mechanisms of the typewriter

are closely interrelated, this manual treats each mechanism in a separate section in order to clarify instructions on maintenance and repair.

2. Orientation

Throughout this manual, front indicates the keyboard side as the operator faces the machine; rear, the side opposite the keyboard side; right, the side on the operator's right; and left, the side on the operator's left.

CHAPTER II

MAINTENANCE AND REPAIR

Section I. DESCRIPTION, MAINTENANCE AND REPAIR TOOLS

3. Description

The Underwood standard typewriter is a carriage shift machine. Each standard model may be equipped with carriages of several different lengths, the length of the carriage being indicated by the prefix or suffix in the serial number of the machine. The serial number is located on the top right side of the frame of the machine.

4. Maintenance and Repair Tools

Special tools for the maintenance and repair of Underwood standard typewriters are included in Tool Set, Office Machine Repair (Federal Stock No. 5180-00-19004; QM Stock No. 41-T-03538-075). The following stock numbers of these tools are included for identification purposes only:

Index No. (DA supply manual QM 5-51, 52)	Quantity	Item	Federal Stock No.	Quartermaster Stock No.
69	1	Bender, backspacer link	5120-449-3740	41-B-00549-000
165	1	Wrench, alining	5120-359-6659	41-W-03800-000
169	1	Wrench, escapement	5120-359-6660	41-W-03805-000

Section II. COVER PLATES

5. General

Cover plates (fig. 1) are designed to protect the machine from foreign matter and to discourage unauthorized personnel from tampering with the internal mechanism. The plates also minimize the noise of the machine. They are removed when necessary for the maintenance and repair of parts.

6. Front Nameplate

a. Removal.

- (1) Place hand above and behind front scale plate (2, fig. 1) and push nameplate (4) toward front of machine.
- (2) Remove nameplate.

b. *Adjustments After Removal.* Form spring studs (5, fig. 1) on reverse side of nameplate to insure a snug fit. Fit liplike extension on lower edge of plate

behind key lever comb. Form as necessary to insure a tight fit.

c. Installation.

- (1) Place liplike extension on lower edge of nameplate behind key lever comb so that spring studs will go into proper holes in frame of machine.
- (2) Hold plate firmly and push plate toward rear of machine until spring studs snap into position.

7. Left Subcarriage Frame End Cover Plate

a. Removal.

- (1) Remove the two binding screws in top of left subcarriage frame end cover plate (10, fig. 1).
- (2) Remove plate.

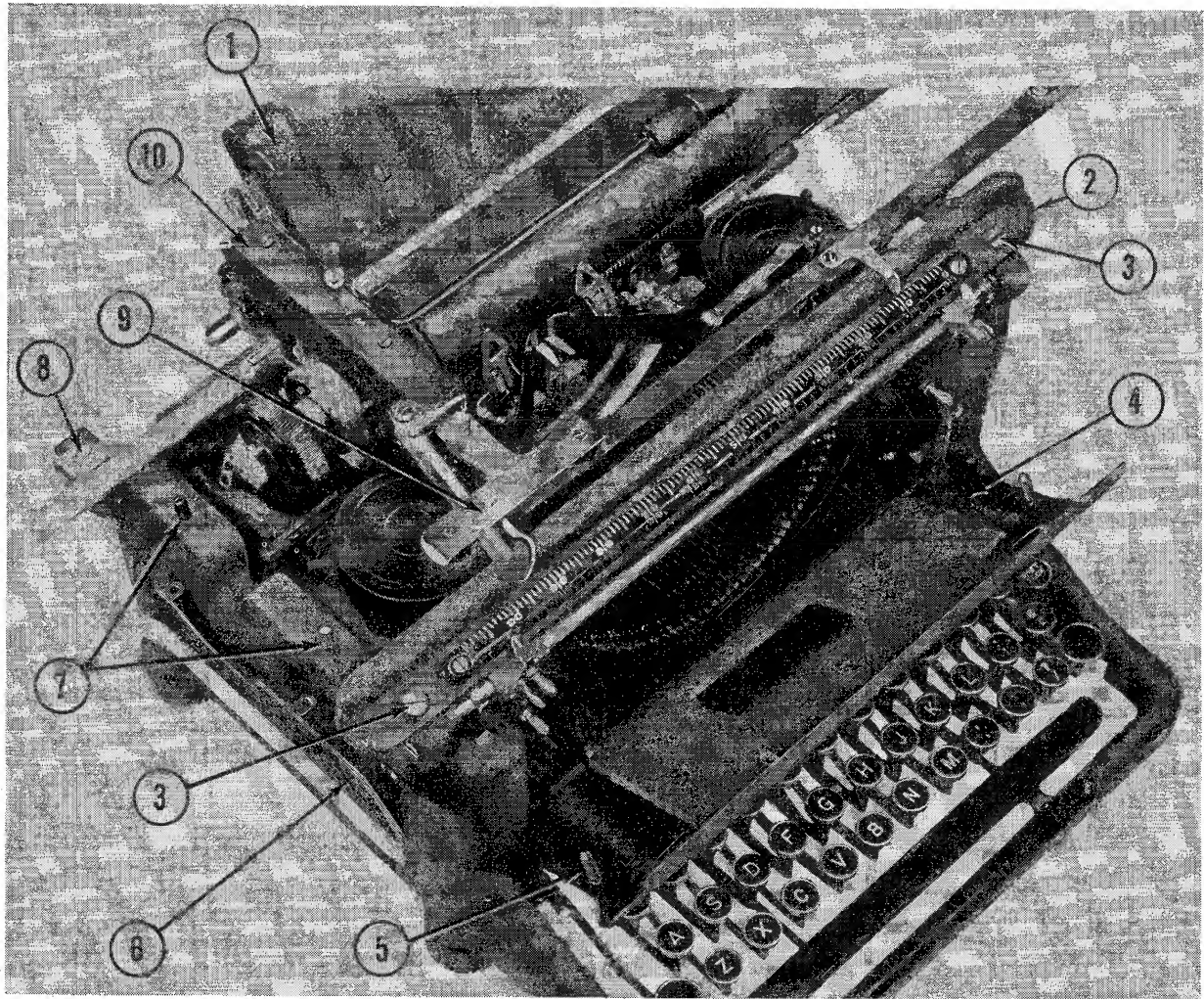

- 1 Lateral paper guide
- 2 Front scale plate
- 3 Front scale plate screws
- 4 Front nameplate
- 5 Spring studs

- 6 Left side frame cover plate
- 7 Left side cover plate binding screws
- 8 Wayrod bracket screw
- 9 Space lever cover plate
- 10 Left subcarriage frame end cover plate

Figure 1. Underwood standard typewriter cover plates, top view.

b. Installation.

- (1) Replace left subcarriage frame end cover plate in proper position.
- (2) Replace and tighten screws.

8. Right Subcarriage Frame End Cover Plate

a. Removal.

- (1) Remove the two binding screws in top of right subcarriage frame end cover plate (not shown in fig. 1).
- (2) Remove plate.

b. Installation.

- (1) Replace right subcarriage frame end cover plate in proper position.
- (2) Replace and tighten screws.

9. Left Side Frame Cover Plate

a. Removal.

- (1) Remove the two left side frame cover plate binding screws (7, fig. 1) on top of left side frame.
- (2) Remove cover plate (6).

b. *Installation.*

- (1) Replace cover plate in proper position.
- (2) Replace and tighten screws.

10. Right Side Frame Cover Plate

a. *Removal.*

- (1) Hold ribbon drive shaft extension with wrench and remove ribbon winding handle screw, washer, and ribbon winding handle (not shown in fig. 1). Turn screw counter-clockwise.
- (2) Remove the two binding screws from top of right side frame.
- (3) Remove cover plate.

b. *Installation.*

- (1) Replace cover plate in proper position.
- (2) Replace and tighten screws.
- (3) Replace ribbon winding handle, handle washer, and handle screw.

- (4) Tighten screw while holding shaft extension with wrench.

11. Left Rear Cover Plate

a. *Removal.*

- (1) Remove the two binding screws.
- (2) Remove cover plate.

b. *Installation.*

- (1) Replace cover plate in proper position.
- (2) Replace and tighten screws.

12. Right Rear Cover Plate

a. *Removal.*

- (1) Remove the two binding screws.
- (2) Remove cover plate.

b. *Installation.*

- (1) Replace cover plate in proper position.
- (2) Replace and tighten screws.

Section III. MAIN CARRIAGE MECHANISM

13. General

Proper fitting of the carriage (fig. 2) is essential in the control of the alinement of type. Loose play must be reduced to the minimum. An understanding of the functions and methods of adjustment of the component assemblies is necessary before adjustment of the mechanism as a whole.

14. Components

a. *Carriage Frame Bearings Assembly and Wayrod.*

The carriage frame bearings assembly consists of two roller bearings (9, fig. 2) and a sleeve (10). The bearings are attached to the underside of the carriage at each end and to the rear. Each carriage frame bearing roll contains 17 ball bearings, held in place by a lead keeper. The sleeve (10) fits over the wayrod (12), which is attached to the frame of the machine by the wayrod brackets, held secure by a binding screw in each bracket.

- (1) *Function.* The bearings are positioned to provide a smoothly operating carriage. The sleeve holds the rolls in contact with the wayrod, which supports the rear of the carriage.
- (2) *Adjustment.* See that the wayrod is clean, well oiled, and true its entire length. If brackets are not secure on the machine, tighten screws holding brackets to machine.

The main carriage guide, located on the right end of carriage (part of the tabulator rack bracket) as you face the machine from the rear, must be as close as possible to the wayrod without creating a bind. The carriage frame bearings must be securely fastened to the main carriage by two screws in each bearing. If the bearings have other than .003-inch up-and-down movement, remove carriage (par. 65a) and enlarge or reduce opening of bearing as necessary. To enlarge opening, form sleeve; to reduce opening, close sleeve in vise. If lead keeper that holds bearing rolls in place is loose, tighten roll binding screw. If keeper is missing, replace. Be sure rolls are free, clean, and well oiled.

b. *Carriage Frame Rolls and Front Scale Plate.*

- (1) *Function.* The carriage frame rolls (3 and 4, fig. 2), attached to the front of the main carriage, travel in the groove of the front scale plate (2) to provide a smoothly operating carriage. The front scale plate supports the front of the carriage. The right carriage frame roll, which is equipped with an eccentric stud, controls the up-and-down movement of the carriage.
- (2) *Adjustment.* To remove excess up-and-

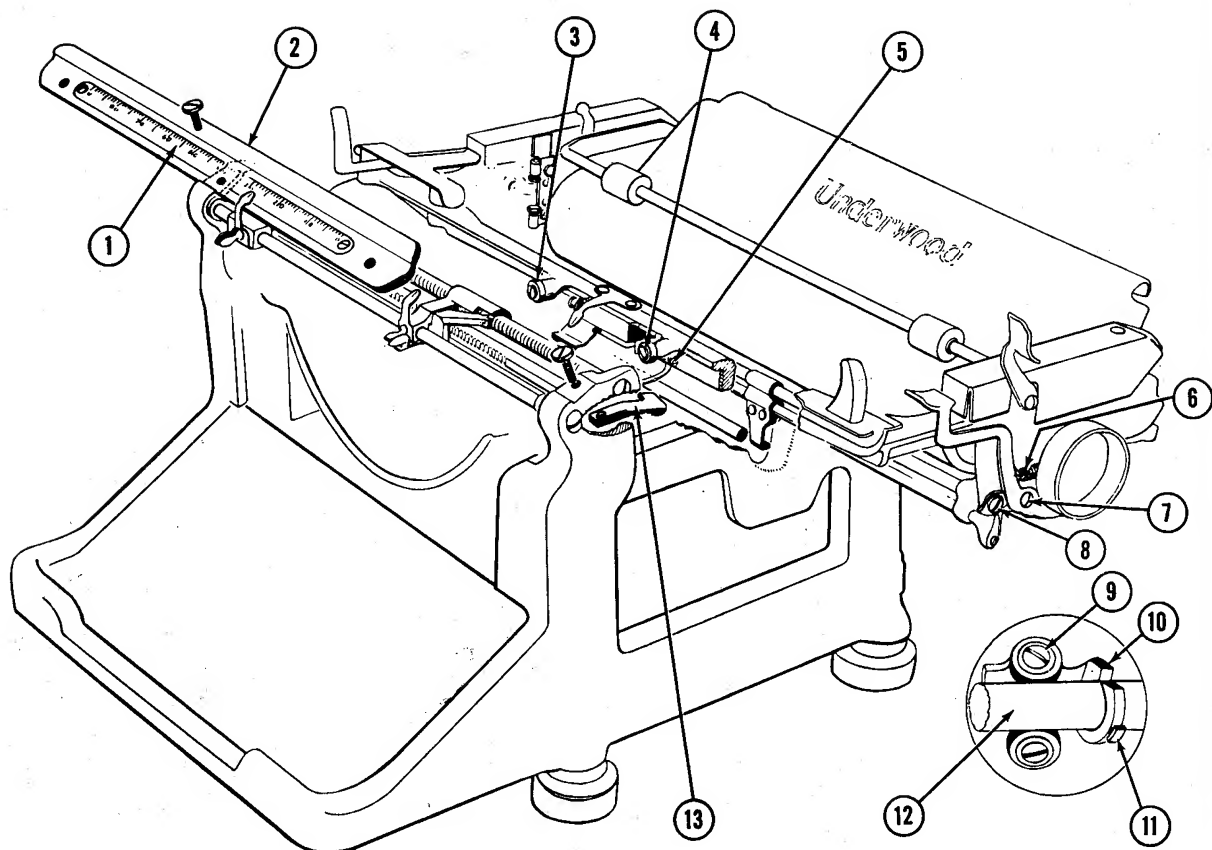

- | | |
|--|-----------------------------------|
| 1 Front scale | 8 Carriage controlling link screw |
| 2 Front scale plate (unseated) | 9 Carriage frame roller bearing |
| 3 Left carriage frame roll | 10 Carriage frame bearing sleeve |
| 4 Right carriage frame roll | 11 Drawband stud |
| 5 Carriage frame roll eccentric stud binding screw | 12 Wayrod |
| 6 Carriage rack frame release lever spring | 13 Carriage frame stop |
| 7 Carriage rack frame end fulcrum screw | |

Figure 2. Main carriage.

down play adjust the right carriage frame roll by loosening carriage frame roll eccentric stud binding screw (5) and turning eccentric stud so that roll just clears upper section of front scale plate. Tighten binding

screw to lock stud in position. The front scale plate must be removed in order to make adjustment, but check for up-and-down play must be made with front scale plate on machine.

Section IV. MAINSPRING MECHANISM

15. General

The mainspring mechanism (fig. 3) supplies the tension necessary to pull the carriage from right to left and to wind the ribbon from one spool to another. Never increase the tension of mainspring to overcome a bind. Before making any adjustment to the mainspring mechanism be sure that the carriage is free. It is necessary to understand the functions and

adjustments of the component assemblies of the mainspring mechanism before attempting removal and installation of it.

16. Components

a. Hanger.

- (1) *Function.* The hanger (7, fig. 3), attached to the frame of the machine by two hanger

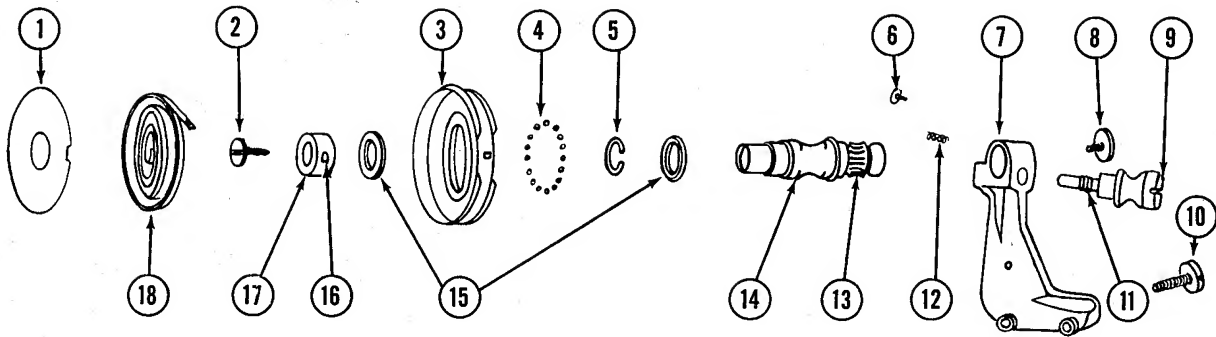

- | | |
|--|----------------------------------|
| 1 Spring drum cover plate | 10 Hanger screw |
| 2 Anchor collar screw | 11 Worm gear |
| 3 Mainspring drum and drawband anchor stud | 12 Tension adjusting knob spring |
| 4 Ball bearings | 13 Gear |
| 5 Cone spacer | 14 Spring drum shaft |
| 6 Tension adjusting knob spring screw | 15 Bearing cones |
| 7 Hanger | 16 Anchor collar stud |
| 8 Shaft binding screw | 17 Anchor collar |
| 9 Tension adjusting knob | 18 Mainspring |

Figure 3. Mainspring (exploded view).

binding screws (3, fig. 4), supports the mainspring assembly.

- (2) *Adjustment.* To secure hanger to machine frame tighten the two hanger binding screws.

b. Spring Drum Shaft.

- (1) *Function.* The geared end of the spring drum shaft (14, fig. 3), upon which the spring drum (3, fig. 3 and *d* below) rotates, fits into the end of the hanger (7) and is held secure by a shaft binding screw (8) threaded into the end of the shaft.

- (2) *Adjustment.* To remove end play, tighten binding screw.

c. Tension Adjusting Knob.

- (1) *Function.* The tension adjusting knob (9, fig. 3 and 4, fig. 4) fits into hanger adjacent to shaft entrance. The worm gear (11, fig. 3) of adjusting knob meshes with gear on spring drum shaft to secure proper adjustment. The tension adjusting knob spring (12, fig. 3 and 6, fig. 4) fits over the end of the knob and rests on a shoulder within the hanger. The binding screw (6, fig. 3 and 2, fig. 4) is threaded into the end of the knob and holds the gears in mesh and the spring in place.

- (2) *Adjustment.* To increase tension on mainspring, turn adjusting knob clockwise. To decrease tension, turn knob counterclockwise. Obtain approximate tension by turn-

ing knob at least 8 full turns. Check tension by placing carriage so that carriage frame pointer is 15 spaces from left end of front scale. Depress spacebar. Carriage should move with snappy action. Never increase mainspring tension by turning the binding screw in end of shaft. Such practice

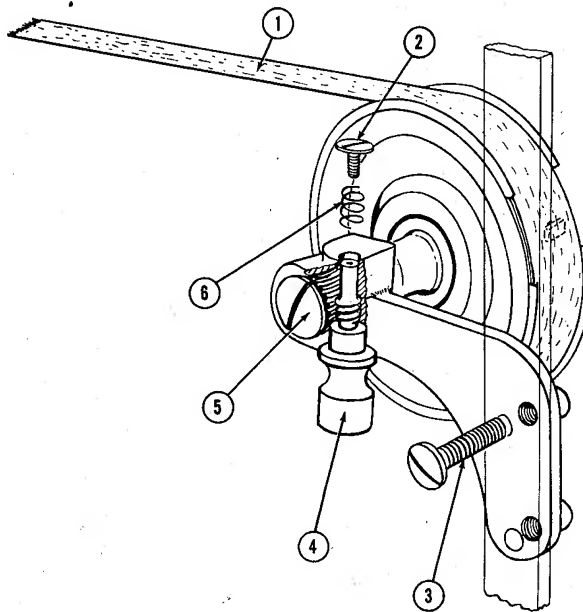

- | |
|---------------------------------------|
| 1 Drawband |
| 2 Tension adjusting knob spring screw |
| 3 Hanger screw |
| 4 Tension adjusting knob |
| 5 Spring drum shaft screw |
| 6 Tension adjusting knob spring |

Figure 4. Mainspring (assembly).

will strip the teeth of the shaft or the adjusting knob and may also snap the mainspring.

d. Drum.

- (1) *Function.* The drum (3, fig. 3) rotates on ball bearings (4). It houses the mainspring (18) and transfers the spring tension to the drawband.
- (2) *Adjustment.* To free drum of end play be sure ball bearings, cone spacer (5), and cones (15) are in proper position. Tighten anchor collar screw (2) to hold anchor collar (17) securely in place. Remove spring drum assembly (par. 66a) to tighten anchor collar screw.

e. Drawband.

- (1) *Function.* The drawband (1, fig. 4), connected from a stud on the mainspring drum (3, fig. 3) to a stud on the right carriage frame bearing, transfers the tension of the mainspring to the carriage.
- (2) *Adjustment.* Be sure that short clip of drawband is hooked to stud on mainspring drum and long slot of long clip is hooked to drawband stud on carriage frame bearing. The short slot is used only when hooking drawband to anchor stud on frame of machine.

Section V. LINE SPACE MECHANISM

17. General

For proper operation of a typewriter, the line space, variable, and paper feed mechanisms are interdependent. The line space mechanism (fig. 5) is designed to rotate the cylinder. It raises the typing paper 1, 2, or 3 spaces within one operation. Before making any adjustments to the line space mechanism, be sure that all parts are free acting and in good condition.

18. Components

a. Line Space Lever.

- (1) *Function.* The line space lever (12, fig. 5), when pushed from left to right, causes the tip of the lever (9) to contact and push the line space plunger (18) rearward.
- (2) *Adjustment.*
 - (a) In the proper inactive position the line space lever tip (9, fig. 5) should lightly touch the line space plunger (18). To make line space lever tip contact line space plunger, loosen the left stop eccentric stud screw (14) and lift eccentric stud (15) to clear pin (16) in main carriage. Position eccentric stud and tighten screw.
 - (b) In full active position, the line space lever must have turned the cylinder ratchet (20) exactly 1, 2, or 3 spaces as has been predetermined by the line space adjusting lever (1). If line space lever does not properly turn the cylinder ratchet, loosen right stop eccentric stud

screw, position eccentric stud so that it will allow the line space lever to move the required distance, and tighten screw. It is sometimes necessary to adjust the line space lever eccentric pivot stud (13) to obtain the proper active position. To adjust, loosen nut, lift stud, place it in proper position, and tighten nut. If line space lever is broken or deformed, replace with new lever. If line space lever stud rubbers are swollen or cut, replace with new rubbers.

b. Line Space Pawl.

- (1) *Function.* The line space pawl (19, fig. 5), forced rearward by the plunger to which it is attached, rides over and drops off the flat protrusion of the line space adjusting lever extension (2). The pawl spring (7) forces the pawl into the teeth of the ratchet and the pawl forces the ratchet rearward.
- (2) *Adjustment.* If the line space pawl, in the active position (with line space lever (12) held against right stop stud rubber (11)), does not clear the pawl stop (22) by .005 inch to .010 inch (6), form bottom of pawl stop for adjustment. Be careful not to disturb upper portion of stop. Form pawl spring tip down to increase tension applied to pawl. (Remove spring in order to form.)

c. Line Space Plunger.

- (1) *Function.* The plunger, forced rearward by the line space lever, carries the pawl rearward.

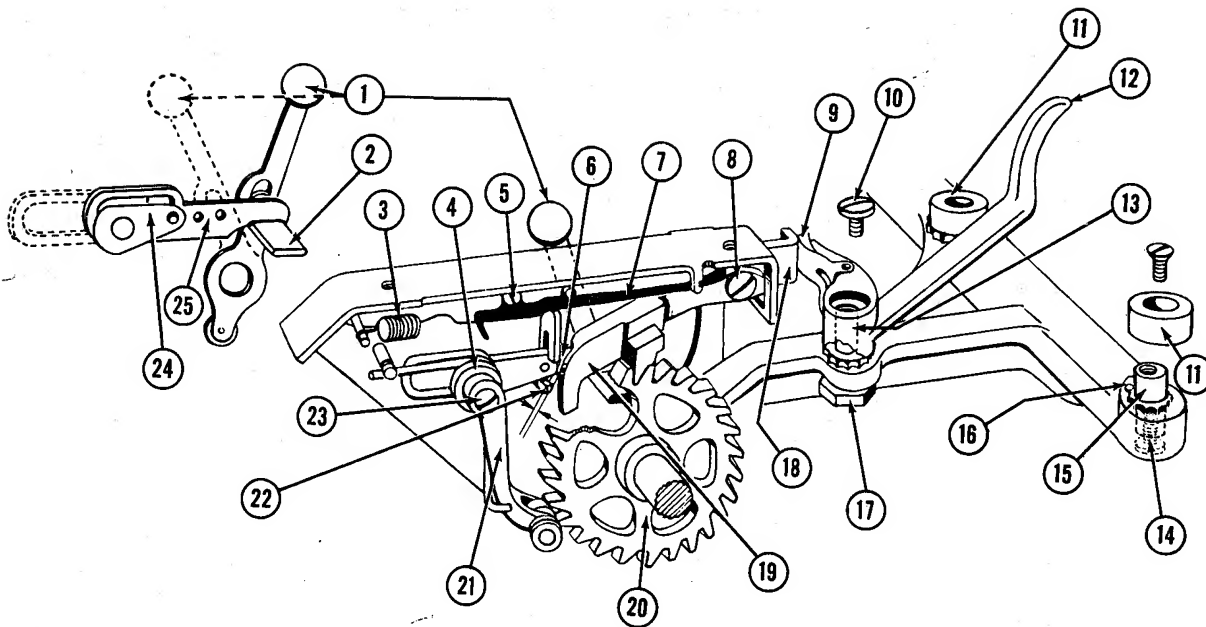

- | | |
|--|--|
| 1 Line space adjusting lever | 14 Left stop eccentric stud screw |
| 2 Adjusting lever extension | 15 Left stop eccentric stud |
| 3 Plunger spring | 16 Pin |
| 4 Detent spring | 17 Line space lever eccentric pivot stud nut |
| 5 Line space pawl spring screw | 18 Line space plunger |
| 6 Clearance, .005 to .010 inch | 19 Line space pawl |
| 7 Line space pawl spring | 20 Cylinder ratchet |
| 8 Line space pawl screw | 21 Line space detent arm |
| 9 Line space lever tip | 22 Pawl stop |
| 10 Line space lever pivot screw | 23 Detent arm screw |
| 11 Right stop stud rubber | 24 Line space adjuster flat tension spring |
| 12 Line space lever | 25 Line space adjuster |
| 13 Line space lever eccentric pivot stud | |

Figure 5. Line space mechanism.

(2) *Adjustment.* The plunger spring (3, fig. 5) must have sufficient tension to return the plunger to its inactive position. Shorten spring to increase tension.

d. *Line Space Detent.*

(1) *Function.* The line space detent arm (21, fig. 5), seated between two teeth of the ratchet, holds the cylinder stationary and forces type to print in a straight line. The line space detent roll should always be in perfect condition to control the line of writing.

(2) *Adjustment.* All parts of the line space detent must be free-acting. The detent spring (4) must have sufficient tension to hold ratchet and insure an even writing line. To increase tension, form end of spring at stud upward. To decrease tension, form end of

spring downward. If roll becomes pitted or worn, replace with new roll.

e. *Line Space Detent Release Lever.* The line space detent release lever (not shown in fig. 5) when pulled forward disengages the detent roll from the teeth of the ratchet and allows the cylinder to turn freely.

f. *Line Space Adjusting Lever.*

(1) *Function.* The line space adjusting lever (1, fig. 5) allows the operator to select 1-, 2-, or 3-line spacing as may be desired. The lever positions the flat extension (2) and thus governs the entry of the line space pawl into the teeth of the ratchet.

(2) *Adjustment.* If the flat spring (24) of the line space adjuster does not have enough tension to hold the lever in place, form spring for proper tension. Replace with new spring if necessary.

Section VI. VARIABLE MECHANISM

19. General

The variable mechanism (fig. 6) is designed to change the line of writing. The friction bands (9), applying friction against the line space drum (8), determine the proper operation of the variable mechanism. Before attempting any adjustment to the variable mechanism, check to see that all parts of the variable are in good condition.

20. Components

a. Variable Line Space Knob.

- (1) *Function.* The variable line space knob (17, fig. 6) houses the variable pushbutton (16, fig. 6), cone lock rod (15), lock rod lever (1), cone rod separator (12), and cone (2). The knob is used to rotate the cylinder.
- (2) *Adjustment.* Be sure that the variable line space knob is positioned properly on shaft with cylinder knob screw (13) securely tightened against shaft and with setscrew (14) securely tightened against knob screw (13).

b. Variable Pushbutton.

- (1) *Function.* The variable pushbutton (16, fig. 6) when pushed in forces the line space cone (2) between the expander levers (10). By spreading the expander levers the cone causes the levers to apply pressure to the friction band pins (11). The friction band pins when forced outward hold the friction bands (9) tight against the drum. The pushbutton is locked in this position by the cone lock rod lever (1). The lock rod lever is forced behind the lock rod (15) by a small spring.
- (2) *Adjustment.* If the locking action of the variable pushbutton does not take place, loosen cylinder knob screw setscrew (14) and cylinder knob screw (13), push variable pushbutton in, and position variable cylinder knob until the lock rod lever (1) drops behind the cone lock rod (15). Tighten cylinder knob screw (13) and cylinder knob screw setscrew (14).

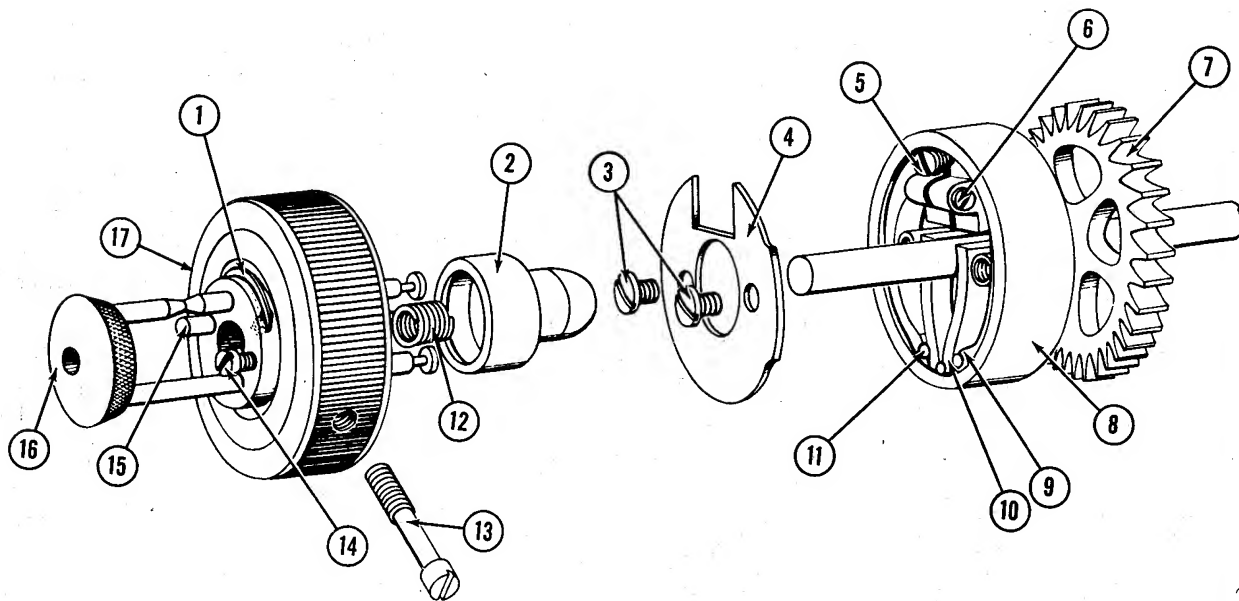

- 1 Cone lock rod lever
- 2 Line space cone
- 3 Line space drum cover plate screws
- 4 Drum cover plate
- 5 Adjusting screw
- 6 Adjusting screw setscrew
- 7 Ratchet
- 8 Line space drum
- 9 Friction band

- 10 Expander levers
- 11 Friction band pin
- 12 Cone rod separator
- 13 Cylinder knob screw
- 14 Cylinder knob screw setscrew
- 15 Cone lock rod
- 16 Variable pushbutton
- 17 Variable line space knob

Figure 6. Variable mechanism.

c. *Line Space Drum.*

- (1) *Function.* The friction applied to the line space drum (8, fig. 6) by the friction bands forces the drum and ratchet to turn with the variable cylinder knob and shaft.
- (2) *Adjustment.* When the variable pushbutton (16) is pushed in, the friction bands must have sufficient pressure to prevent slippage. When the button is pulled out, the bands

must release pressure to allow knob and cylinder to turn freely. Remove variable line space knob and drum cover plate as directed in paragraph 67d. Loosen variable adjusting screw setscrew (6) and turn adjusting screw (5) clockwise to increase friction or counterclockwise to decrease friction. Tighten setscrew and return other parts of variable mechanism.

Section VII. PAPER FEED MECHANISM

21. General

The paper feed mechanism (figs. 7 and 8) feeds the paper from line to line and positions the paper for typing.

22. Components

a. *Cylinder.*

- (1) *Function.* The cylinder (fig. 7) provides the backing necessary for a type impression. When the paper feeds into the machine, it curves around the cylinder. The paper

holder bail (1) holds the paper flush against the cylinder to insure a clear type impression and to decrease the noise when the type strikes the paper.

- (2) *Cleaning.* Check cylinder when trouble occurs in paper feed mechanism because of carbon collection on the surface. Foreign matter collecting on the cylinder will create a glossy appearance and cause the cylinder to lose traction and thus allow paper to slip. Clean off gloss with alcohol or a similar cleaning substance.

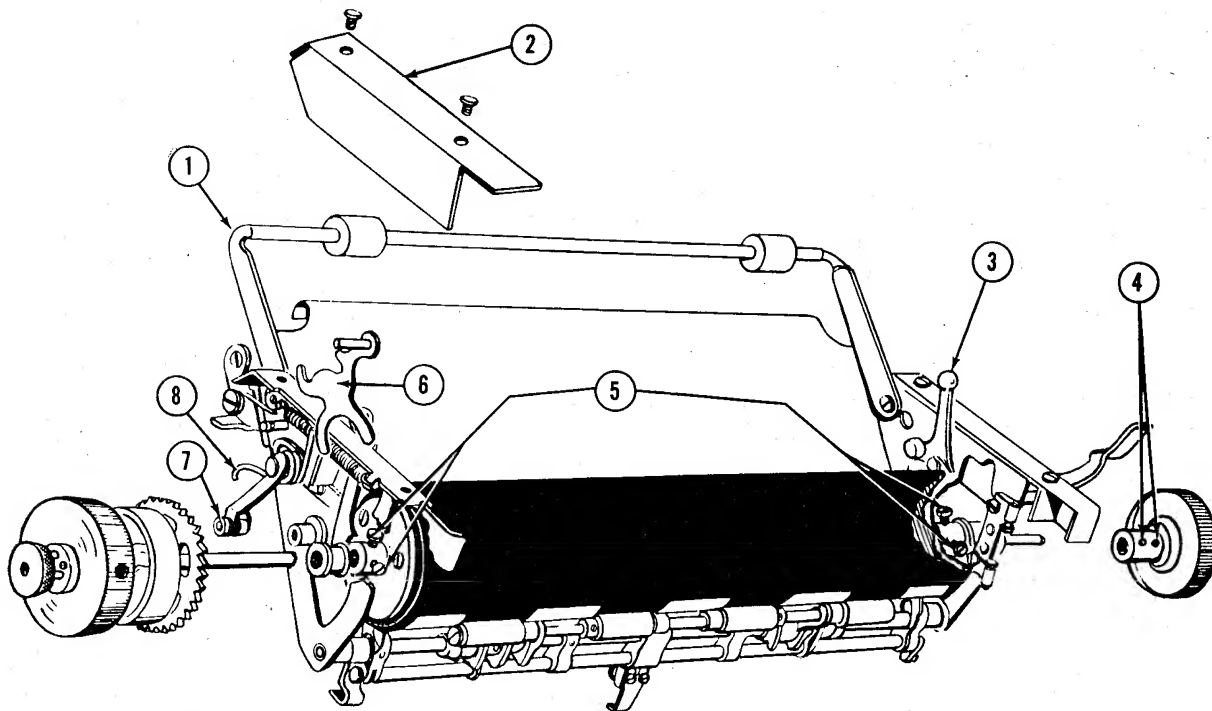

- 1 Paper holder bail
- 2 Cover plate
- 3 Paper holder bail release lever
- 4 Cylinder shaft knob screws

- 5 Cylinder shaft screws
- 6 Line space disengaging cam
- 7 Detent
- 8 Detent arm spring

Figure 7. Cylinder, with variable mechanism and items (2, 4, and 6) removed from the assembly.

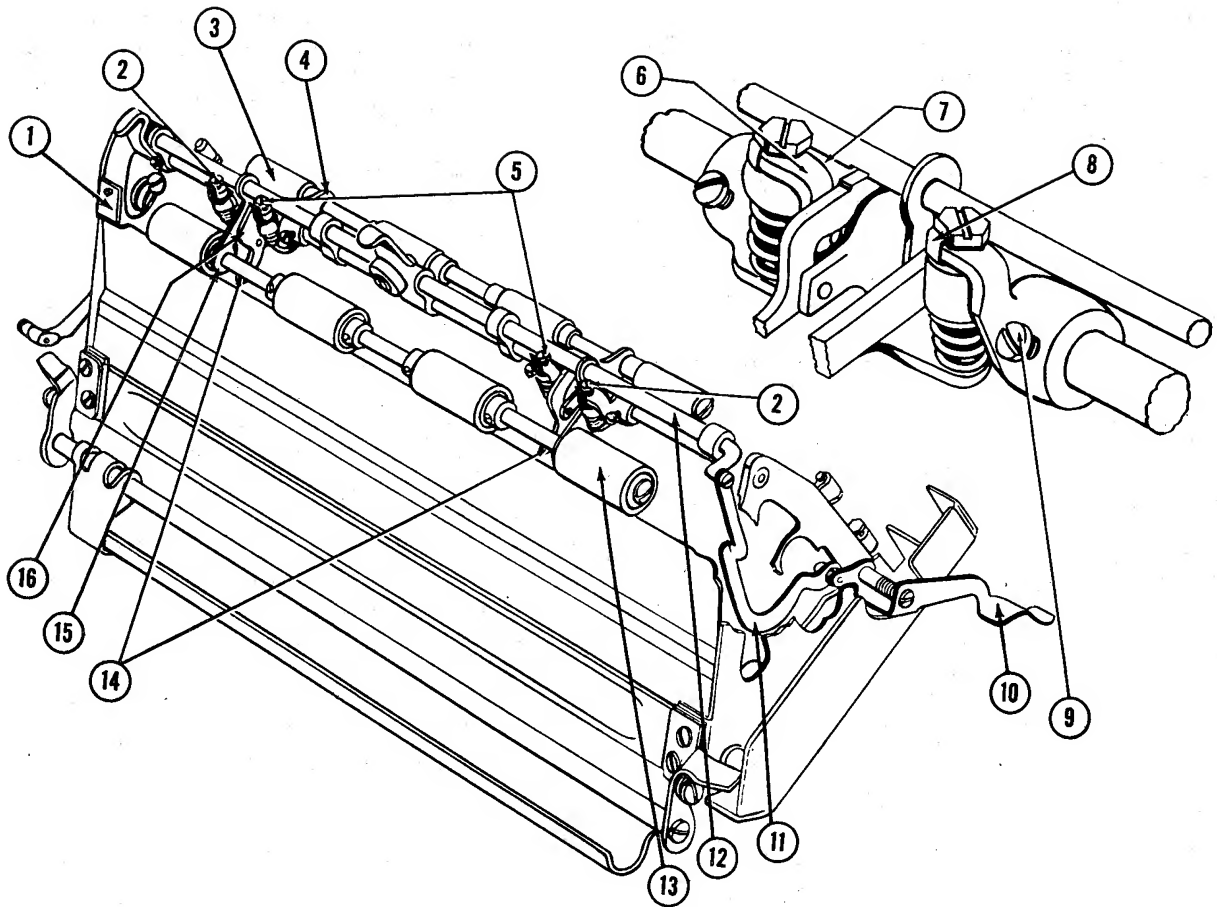

- 1 Paper table holding bracket
- 2 Rear feed roll tension adjusting screw
- 3 Front feed roll
- 4 Front feed roll hanger
- 5 Front feed roll tension adjusting screws
- 6 Feed roll tension spring retainer
- 7 Clearance, .003 inch
- 8 Adjusting screw lock

- 9 Spring retainer setscrew
- 10 Feed roll release lever
- 11 Roll release connecting link
- 12 Roll release rod
- 13 Rear feed roll
- 14 Clearance between rod and lever, .003 inch
- 15 Rear feed roll hanger
- 16 Feed roll hanger release lever

Figure 8. Paper feed mechanism, bottom view.

(3) *Adjustment.*

- (a) Check to see that cylinder is round. If the cylinder is not round the feed rolls will not have even pressure against the cylinder and the ring and cylinder will be affected. Rotate cylinder rapidly and observe it to see if it has a wobbly appearance. Replace cylinder (par. 67) if it appears to wobble.
- (b) When cylinder binds on carriage ends, shave off cylinder end with a platen end reamer. The cylinder must turn freely without end play. To remove end play of cylinder, pull shaft out to left and insert washers or shims on shaft to the right of

cylinder between cylinder end and sub-carriage skeleton. Replace or straighten cylinder shaft if it is deformed.

b. *Paper Table.*

- (1) *Function.* The paper table (fig. 8) holds the typing paper as it is fed between the cylinder and the feed rolls.
- (2) *Adjustment.* If paper table does not clear cylinder by .070 inch, form paper table holding brackets (1).

c. *Cylinder Shield.*

- (1) *Function.* The cylinder shield (not shown in fig. 8), located just beneath the cylinder, is held in place by forked ends resting on the subcarriage skeleton. The shield is

slotted on front and rear sides to allow the feed rolls to contact paper and hold it against the cylinder.

- (2) *Adjustment.* If cylinder shield does not clear entire length of cylinder, form bumper ends to just contact paper table and form front end to clear cylinder by .010 to .012 inch. Caution must be taken when forming paper pan. Use paper pan bender tool.

d. Front and Rear Feed Rolls.

- (1) *Function.* The front feed rolls (3, fig. 8) and rear feed rolls (13) feed the typing paper around the cylinder. The rolls revolve on a shaft that is held in place by hanger arms connected to the subcarriage skeleton.
- (2) *Adjustment.*
 - (a) Replace rolls (par. 67e) if they are not perfectly round. A maladjusted or swollen feed roll will cause poor paper feed. The tension of the feed rolls should be uniform and not excessive.
 - (b) To test for uniform tension, insert a strip of paper between feed roll and cylinder and pull paper for slippage. Test each roll in the same manner. To adjust, move carriage as far as possible to left or right as desired to provide access to feed roll tension adjusting screws (2 and 5) from underneath the carriage, and turn screws clockwise to increase or counterclockwise to decrease tension. If feed roll tension spring retainers (6) do not clear feed roll release rod (12) by .003 inch, loosen setscrews, position retainer, and

tighten setscrews. Be sure that screw locks (8) contact heads of screws.

e. Paper Release Mechanism.

- (1) *Description.* The paper release mechanism consists of the feed roll release lever (10, fig. 8), roll release connecting link (11), roll release rod (12), and feed roll hangers (4 and 15).
- (2) *Function.* The paper release mechanism forces the rolls from the underside of the cylinder and allows the paper to pass freely around the cylinder.
- (3) *Operation.* When the feed roll release lever is pushed down, it pulls the roll connecting link up. The lower end of the connecting link pivots the roll release rod, and feed roll hanger release levers (16) force rolls and roll shafts away from the cylinder. The upper end of the connecting link forces the paper bail away from the cylinder.
- (4) *Adjustment.* If feed roll hanger release levers (16) do not clear roll release rod by .003 inch (14) when the rolls are against the cylinder, form hanger release levers for adjustment. If feed rolls do not clear the cylinder by .075 inch when released, form hanger release levers (16) for adjustment.

f. Paper Holder Bail.

- (1) *Function.* The paper holder bail (1, fig. 7) holds paper firmly against the cylinder.
- (2) *Adjustment.* Adjust paper holder bail so that there is equal pressure on both rolls by forming bail with hands as necessary.

Section VIII. ESCAPEMENT MECHANISM

23. General

The escapement mechanism (fig. 9) controls the space-by-space movement of the carriage. The escapement mechanism includes a series of links and levers; the universal bar; the escapement rocker assembly; rack, pinion, and escapement wheel assembly; and the spacebar. The interrelated movements of these parts affect the escapement trip.

24. Escapement Trip

a. When the key lever (17, fig. 9) is depressed, it pulls the sublever (18) down.

b. The sublever pulls the tail of the type bar (2) down and pivots the type bar.

c. As the type head (19) travels toward the cylinder, the heel of the type bar will contact and push the universal bar (4) rearward.

d. The rear center part of the universal bar contacts the trip adjusting screw (5) on the top of the rocker and forces the upper half of the rocker rearward.

e. The rocking action of the rocker allows the loose dog (10) protruding from the top of the escapement rocker to release the escapement wheel tooth, which then contacts the rigid dog (6).

f. When the rocker starts back to its normal position, the rigid dog releases the escapement wheel tooth.

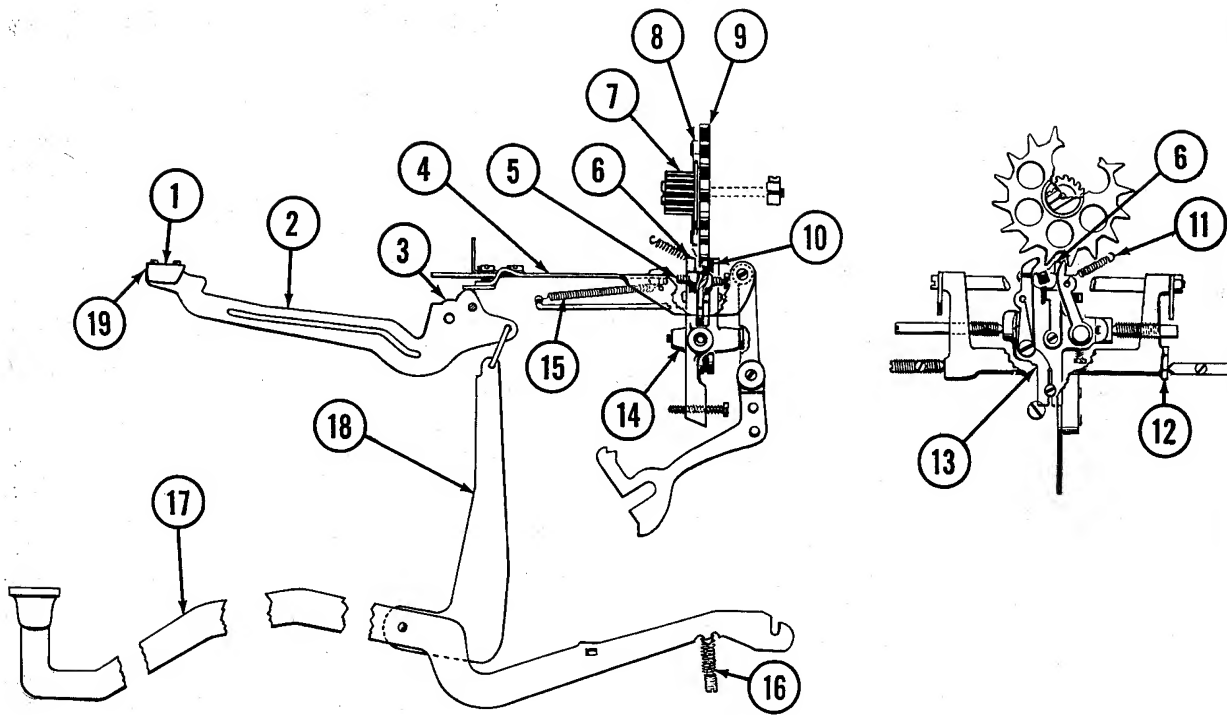

- 1 Typeface
- 2 Type bar
- 3 Camshape
- 4 Universal bar
- 5 Trip adjusting screw
- 6 Rigid dog
- 7 Pinion
- 8 Pinion pawl
- 9 Escapement wheel
- 10 Loose dog

- 11 Loose dog spring
- 12 Rocker arm eccentric
- 13 Rocker (rear view)
- 14 Rocker
- 15 Universal bar spring
- 16 Key lever tension spring
- 17 Key lever
- 18 Sublever
- 19 Type head

Figure 9. Escapement mechanism.

g. The next escapement wheel tooth moves into position against the loose dog and thus completes the escapement trip.

25. Universal Bar

a. *Description.* The universal bar (fig. 10) is held in place by the frame arms (3) fastened to the rocker arms (7) and the universal bar guide (12) fitted through a slot in the segment (1). The blade (14) of the bar fits into an opening in the back of the segment.

b. *Function.* The universal bar when forced rearward by the heel of the type bar contacts the trip adjusting screw and motivates the escapement trip.

c. *Adjustment.*

- (1) *General.* A maladjustment in the universal bar affects the escapement trip, ribbon feed, ribbon reverse, ribbon cover, and line locks. Check all pivot points (after removing two rear cover plates (pars. 11 and 12))

to be sure there is no bind or excessive play. Be sure that universal bar frame arms (3, fig. 10) are fastened to frame shaft (5) with minimum sideplay. See that shaft nut (4) is screwed on shaft with flat side away from frame arm. If too much sideplay exists, form frame arms.

- (2) *Tension.* The spring (10) is hooked to the spring stud and the universal bar spring support (11). The spring must have sufficient tension to return the bar to its normal position in the segment. To adjust, loosen universal spring support lock screw (6), position support (11) as necessary, and tighten lock screw while holding support in proper position. For normal tension the spring support should extend one-fourth of an inch from escapement frame. Have tension as light as possible but with snappy action of universal bar.

(3) *Centering.* The universal bar guide (12) must be centered in the segment guide slot. To adjust, loosen ribbon feed actuating shaft lever (par. 35a), rocker arm fulcrum pivot lever (par. 35a), rocker arm fulcrum pivot screw setscrew (24, fig. 11), and rocker arm pivot pin setscrew (17, fig. 11). Position fulcrum pivot screw (25, fig. 11) and pin (16, fig. 11) until universal bar guide is centered in segment guide slot, hold rocker arm, and tighten lock screws. Tighten ribbon feed actuating shaft lever screw. Be sure actuating lever does not bind universal bar.

(4) *Paralleling blade.* The universal bar blade (14, fig. 10) must be parallel with the segment in order to force all type bars to be equally distant from the type guide when the heel of the type bar contacts the blade. Thus each type bar will move the universal bar an equal distance. To adjust, loosen ribbon feed actuating shaft lever (par. 35a) and universal bar frame stop (13). Hold universal bar in normal position and turn rocker arm eccentric so that when type bars number 1 (Q), number 21 (Y), and number 42 (¢) are raised toward the segment they

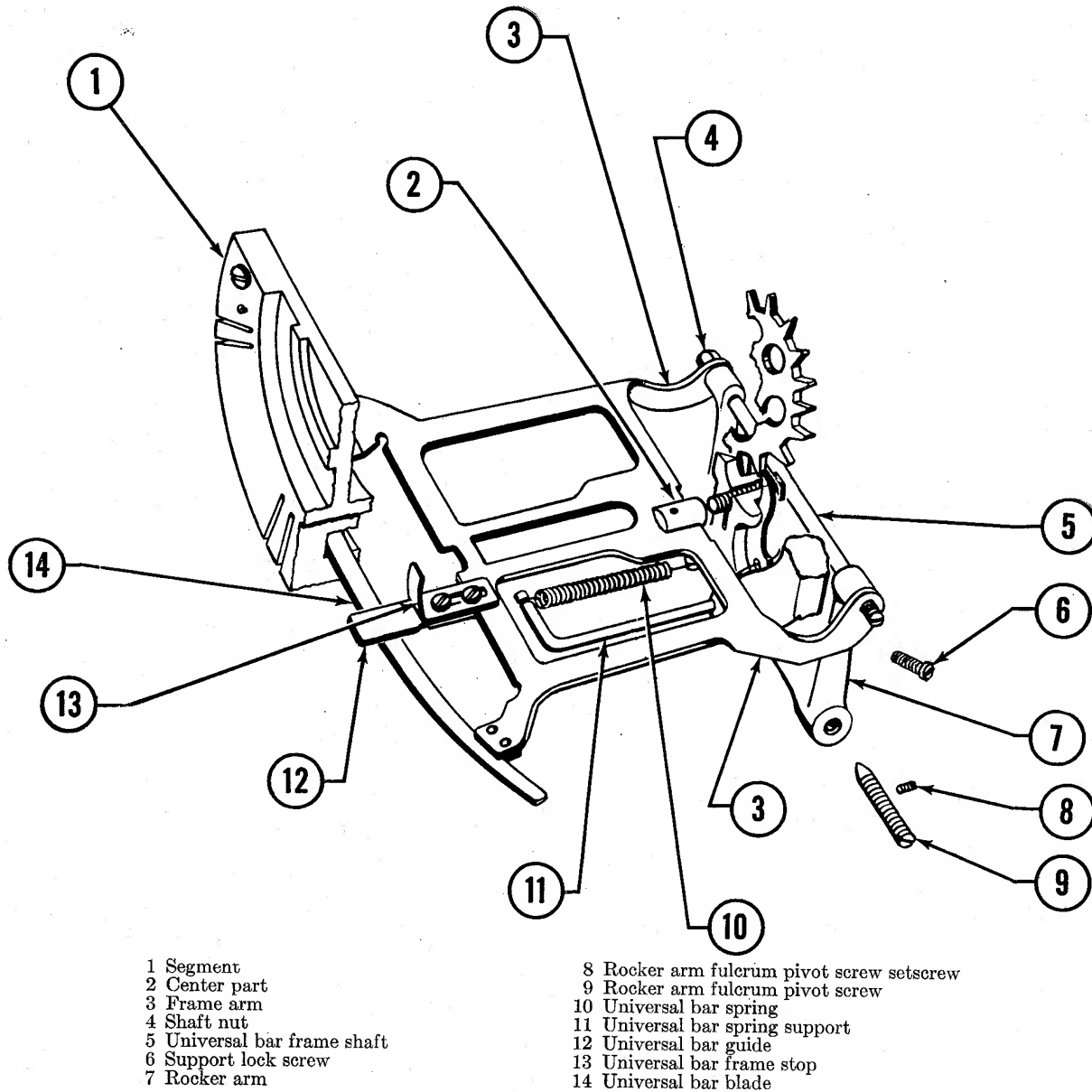

- 1 Segment
- 2 Center part
- 3 Frame arm
- 4 Shaft nut
- 5 Universal bar frame shaft
- 6 Support lock screw
- 7 Rocker arm

- 8 Rocker arm fulcrum pivot screw setscrew
- 9 Rocker arm fulcrum pivot screw
- 10 Universal bar spring
- 11 Universal bar spring support
- 12 Universal bar guide
- 13 Universal bar frame stop
- 14 Universal bar blade

Figure 10. Universal bar.

will be an equal distance from the type guide when the heels of the type bars contact the blade. After proper adjustment has been made, tighten ribbon feed actuating shaft lever screw and universal frame stop screws. Recheck the universal bar centering adjustment.

- (5) *Pickup.* The typeface must be seven-eighths of an inch from the type guide when the heel of the type bar picks up or contacts the universal bar. To adjust, loosen universal bar frame stop screws and position universal bar frame stop (13) forward or rearward as may be necessary to obtain the proper pickup. Hold universal bar frame stop and tighten screws. If this adjustment cannot be obtained, check to see that the spacebar adjusting lever (par. 29c (5)) is

not interfering with universal bar or that bar is not deformed.

26. Escapement Frame

a. *Description.* The escapement frame (fig. 11) is attached to the escapement frame base by two binding screws (18). The frame base is held to the machine frame by four binding screws.

b. *Function.* The escapement frame provides mounting support for the rocker assembly, escapement wheel and pinion, and parts of the backspace, tabulator, and ribbon mechanisms.

27. Escapement Rocker Assembly

a. *Rocker.*

- (1) *Position.* The rocker is held in position in the escapement frame by a pivot screw (3,

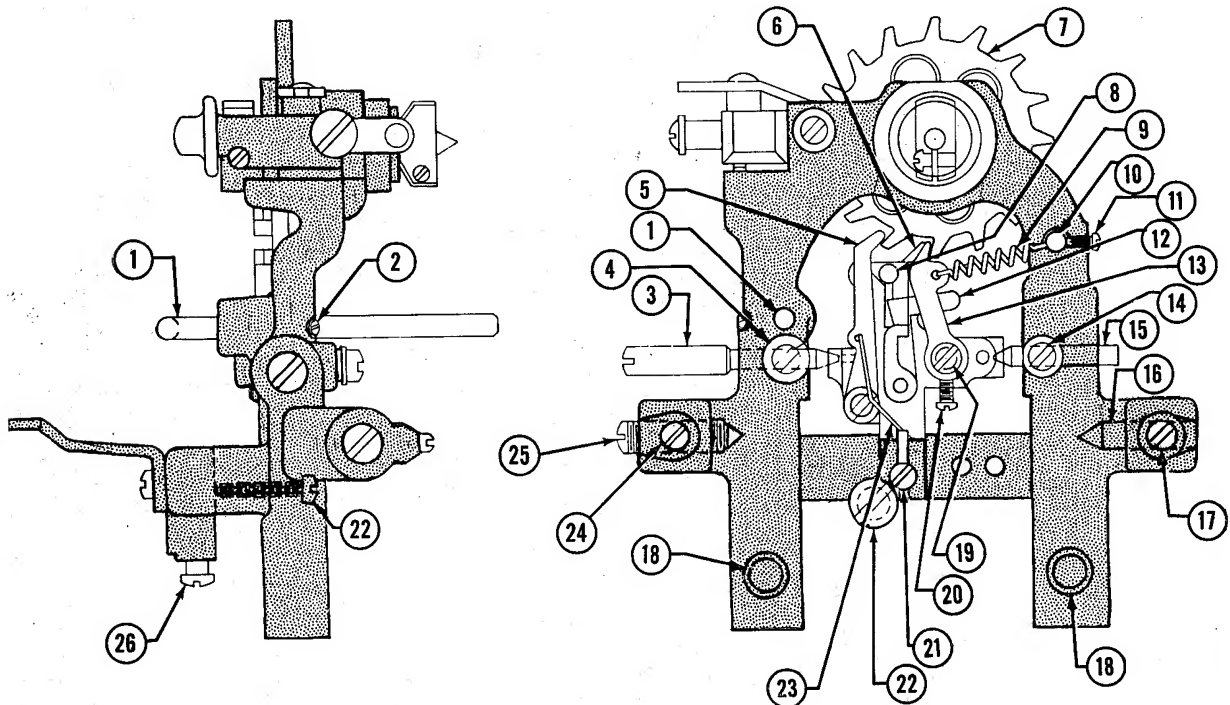

- 1 Universal bar spring support
- 2 Support lock screw
- 3 Rocker pivot screw
- 4 Pivot screw lock screw
- 5 Backlash pawl
- 6 Rigid dog
- 7 Escapement wheel
- 8 Trip adjusting screw
- 9 Loose dog spring
- 10 Loose dog spring support
- 11 Loose dog spring support lock screw
- 12 Loose dog stop
- 13 Loose dog

- 14 Pivot pin lock screw
- 15 Rocker pivot pin
- 16 Rocker arm fulcrum pin
- 17 Rocker arm fulcrum pin setscrew
- 18 Escapement frame binding screw
- 19 Loose dog pivot stud
- 20 Pivot stud setscrew
- 21 Rocker limit screw
- 22 Rigid dog adjusting screw
- 23 Backlash pawl spring
- 24 Rocker arm fulcrum pivot screw setscrew
- 25 Rocker arm fulcrum pivot screw
- 26 Rigid dog adjusting screw lock screw

Figure 11. Escapement mechanism, side and rear views, showing escapement frame and rocker assembly.

fig. 11) and a pivot pin (15), each having a lock screw. The rocker must rock freely on its pivot screw and pivot pin. If the pivot screw or pivot pin is too tight, the rocker will bind. The rocker must be centered in the escapement frame so that the escapement wheel tooth will cover three-fourths of the loose dog (13). There must be a clearance of .025 inch between the escapement wheel tooth and the rigid dog (6). The rocker is motivated by the action of the universal bar.

(2) *Function.* The pivoting of the rocker moves the loose dog off the escapement wheel tooth and thus releases the tooth to contact and slip off the rigid dog.

(3) *Adjustment.*

(a) *Centering.* To center rocker, loosen pivot pin lock screw (14) and backspace pawl carrier eccentric lock screw. Position pin and screw until rocker is centered so that loose dog fits flat against escapement wheel tooth. Hold rocker and tighten lock screws.

(b) *Normal vertical position.* To obtain vertical position, loosen rigid dog adjusting screw lock screw (26) and turn adjusting screw (22) to position rocker so that escapement wheel tooth covers three-fourths of loose dog. Tighten rigid dog adjusting screw lock screw. The head of the adjusting screw must be resting against the bottom of the rocker.

b. *Loose Dog.*

(1) *Position.* The loose dog (13, fig. 11) is fastened to the rocker by a pivot stud (19) and setscrew (20). The loose dog must be free on its pivot. The loose dog shims fit between the loose dog and the rocker and establish a clearance of .052 to .055 inch between the loose dog and the rigid dog. A tension spring (9) applies tension to the loose dog and thus pivots the dog against the loose dog stop (12). The tension of the escapement wheel is much greater than that of the tension spring and easily forces the loose dog against the trip adjusting screw (8).

(2) *Function.* The loose dog holds the escapement wheel and thus prevents any movement when the rocker is in inactive position.

(3) *Adjustment.* To obtain .052- to .055-inch clearance between loose dog and rigid dog, disconnect loose dog spring (9), loosen loose dog pivot stud setscrew (20), and remove loose dog (13) and stud (19). To increase clearance, insert shims of proper thickness and number on loose dog pivot stud. To decrease clearance, remove shims. If no shims are present, file or stone front side of loose dog at its pivot point. Replace dog and stud, tighten lock screw, and connect loose dog spring. If loose dog spring has not sufficient tension to pull dog against loose dog stop, loosen loose dog spring support lock screw (11) and position support to obtain proper tension. Hold support and tighten lock screw.

c. *Loose Dog Stop.*

(1) *Position.* The loose dog stop (12, fig. 11) is fastened to the rocker by a binding screw. The stop must be positioned to maintain a .025-inch clearance between the back edge of the dog and the back edge of the escapement wheel tooth that is in contact with the rigid dog.

(2) *Function.* The loose dog stop controls the inactive position of the loose dog.

(3) *Adjustment.* To adjust stop for proper position, hold type bar against abutment ring and form stop for proper clearance.

d. *Trip Adjusting Screw.*

(1) *Position.* The trip adjusting screw (8, fig. 11) threaded through the top of the rocker, must be positioned so that the universal bar will trip rocker when type head is one-eighth of an inch from cylinder.

(2) *Function.* The trip adjusting screw serves as a contact point for the universal bar as it forces the rocker rearward.

(3) *Adjustment.* Using special escapement wrench, turn adjusting screw clockwise or counterclockwise as may be necessary to bring about escapement trip when type head is one-eighth of an inch from cylinder.

e. *Rocker Limit Screw.*

(1) *Position.* The rocker limit screw (21, fig. 11) is located on the bottom of the rocker. The screw must be positioned to maintain a 1/64-inch clearance between the end of the screw and the escapement frame when the rocker has rocked to its rear position.

- (2) *Function.* The limit screw provides an additional 1/64-inch movement of the rocker.
- (3) *Adjustment.* To adjust the limit screw, hold type bar against abutment ring and turn screw to obtain proper clearance.

f. Backlash Pawl.

- (1) *Position.* The backlash pawl (5, fig. 11) is fastened to the rocker by a binding screw. When the loose dog moves off the escapement wheel tooth (7), the rocker pivots and allows the tooth to pass. The backlash pawl tension spring (23) applies tension to the pawl.
- (2) *Function.* The backlash pawl (5) prevents backlash of the escapement wheel (7) when moving the carriage to the left margin.

28. Carriage Rack, Pinion, and Escapement Wheel Assembly

a. General. The carriage rack, pinion, and escapement wheel assembly (fig. 12), although grouped as a part of the escapement mechanism, actually serves as a tie-in mechanism between the carriage mechanism and the escapement mechanism. The style of type produced by the machine governs the kind of rack, pinion, and escapement wheel on the machine. Pica type has 10 letters per inch of writing line and elite type has 12 letters per inch. Pica parts and elite parts cannot be interchanged.

b. Carriage Rack.

- (1) *Position.* The carriage rack (8, fig. 12) is positioned beneath the carriage on rack arms. Two pins at each end of the rack are inserted through the arms and into the rack. Pivot screws fasten the rack arms to each end of the main carriage.
- (2) *Function.* The rack (8) in mesh with the pinion wheel (3) transfers the mainspring tension from the carriage to the escapement wheel (4). The rack arms raise the rack out of mesh with the pinion and thus allow the carriage to move freely to any desired position.
- (3) *Adjustment.* The rack must be securely fastened to the main carriage without side-play. To adjust, loosen rack end adjusting screw locknut on the left rack arm and position screw so that it barely touches main carriage frame. Hold screw and tighten nut. The rack spring must have sufficient tension to return the rack (8) in mesh with the

pinion (3). The rack meshes as deeply as possible in the pinion without creating a bind. To adjust the position of rack teeth in the pinion, loosen the tabulator lever adjusting screw lock screw (15) and turn the tabulator lever adjusting screw (14) to raise or lower the tabulator lever, lever roll, and rack. When proper position is obtained, tighten lock screw (15).

c. Pinion.

- (1) *Position.* The pinion (3, fig. 12) should be placed on the escapement wheel shaft so that, when viewing the pinion from the front, the teeth lean in a clockwise direction. The pinion pawl (6) should be seated in the teeth of the pinion.
- (2) *Function.* The pinion transfers the carriage tension to the escapement wheel by exerting force on the pinion pawl. The pinion pawl (6), riveted to the escapement wheel (4), forces the escapement wheel to turn. When the carriage is returned, the pinion turns clockwise and forces the pawl out of engagement with the pinion teeth. The pinion turns freely without the escapement wheel turning.
- (3) *Adjustment.* Check to see that small spring (7) located on pinion pawl is applying pressure to pawl (6). Keep pawl engaged in pinion.

d. Escapement Wheel.

- (1) *Position.* The escapement wheel is permanently fixed to its shaft, which is held in place at the top of the escapement frame by the wheel shaft adjusting nut (10). The shaft revolves on 7 ball bearings in the front of the frame, which are held in place by the wheel, and 8 ball bearings in the rear of the frame, which are held in place by the wheel shaft cone (9).
- (2) *Function.* The escapement wheel when controlled by the escapement rocker controls the space-by-space movement of the carriage.
- (3) *Adjustment.* The escapement wheel shaft must be free of end play. To adjust, loosen wheel shaft adjusting nut lock screw (11) and turn adjusting nut (10) clockwise to tighten shaft. Hold nut and tighten lock screw. Be sure that shaft turns freely and does not bind.

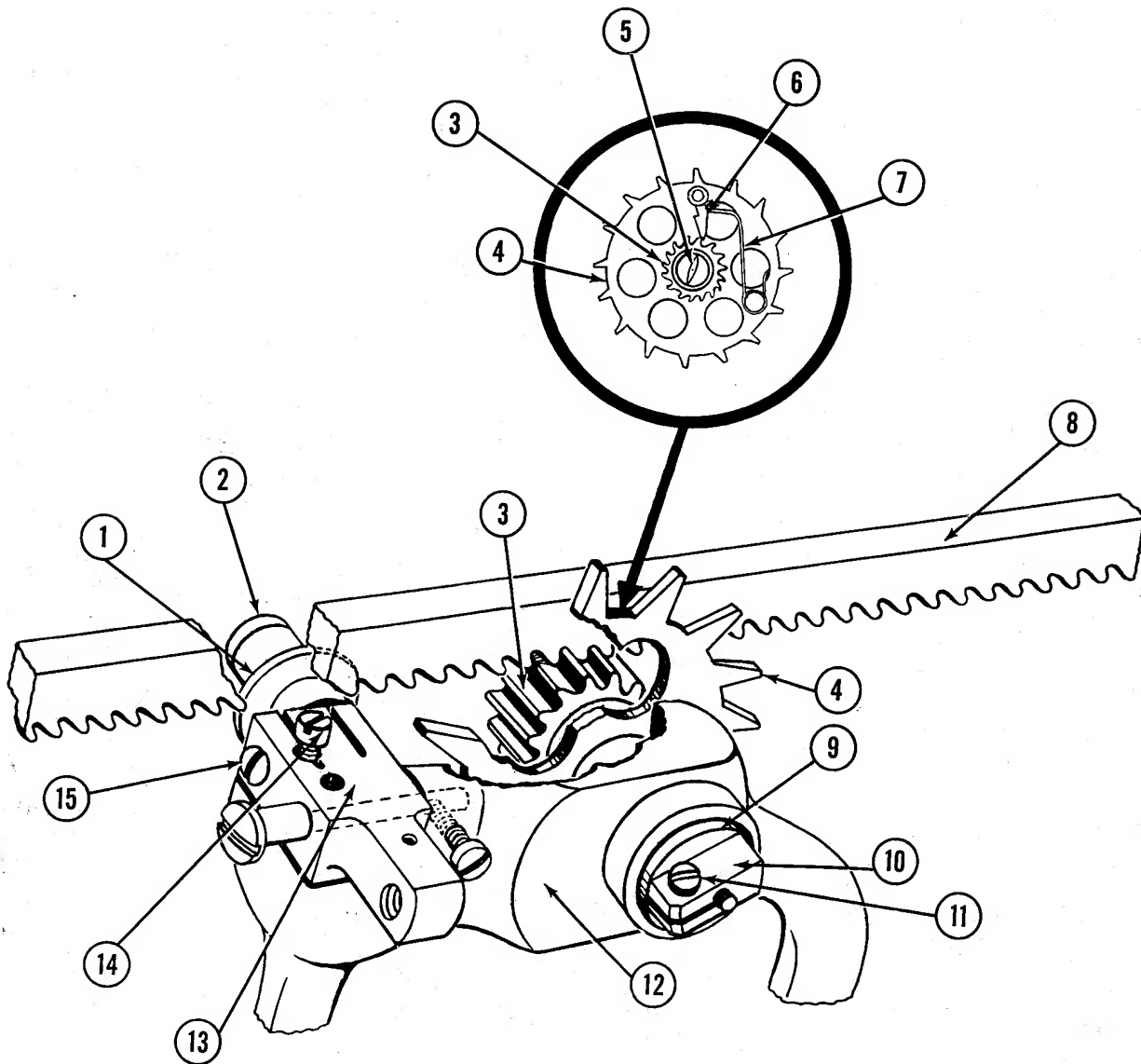

- 1 Tabulator lever roll
- 2 Pivot stud
- 3 Pinion
- 4 Escapement wheel
- 5 Pinion screw
- 6 Pinion pawl
- 7 Pawl spring
- 8 Carriage rack

- 9 Wheel shaft cone
- 10 Wheel shaft adjusting nut
- 11 Wheel shaft adjusting nut lock screw
- 12 Escapement frame
- 13 Tabulator lever
- 14 Tabulator lever adjusting screw
- 15 Tabulator lever adjusting screw lock screw

Figure 12. Carriage rack, pinion, and escapement wheel assembly, rear view.

29. Spacebar Mechanism

a. *Function.* The spacebar mechanism (fig. 13) releases the carriage space by space without creating a type impression.

b. *Operation.* When the spacebar (16, fig. 13) is depressed, the frame levers (1) actuate the spacebar shaft (2). The rear end of the spacebar adjusting

lever (10) is forced upward and contacts the rocker arm extension (3), which forces the extension upward. The extension, riveted to the rocker arm, pivots the arm, which pulls the universal bar toward the rear of the machine and thus causes an escapement trip.

c. *Adjustments.*

(1) *Spacebar shaft.* The spacebar shaft (2, fig.

13) must be free to pivot, but with minimum sideplay. To adjust, insert washers between end of shaft and shaft frame. Be sure washers do not throw shaft off center.

- (2) *Spacebar spring.* The spacebar spring (12) must have sufficient tension to return the bar to its normal position with a snappy action. To adjust, hold spacebar spring adjusting collar (11) and loosen lock screw (13). Position collar to obtain proper tension and tighten lock screw. Position right end of spring in slot provided for it in machine frame.
- (3) *Spacebar.* The normal position of the space-

bar is eleven-thirty-seconds of an inch below the top of the first bank of keys. The spacebar must be level. To adjust, form spacebar stops (15).

- (4) *Spacebar frame levers.* The spacebar frame levers (1) must not interfere with the depressed type bar key levers. To adjust, loosen spacebar frame lever screws on underside of spacebar, position frame levers, and tighten screws. Form frame levers if necessary.
- (5) *Spacebar adjusting lever.* Maintain a .010- to .020-inch clearance (9) between the tip of the spacebar adjusting lever (10) and the

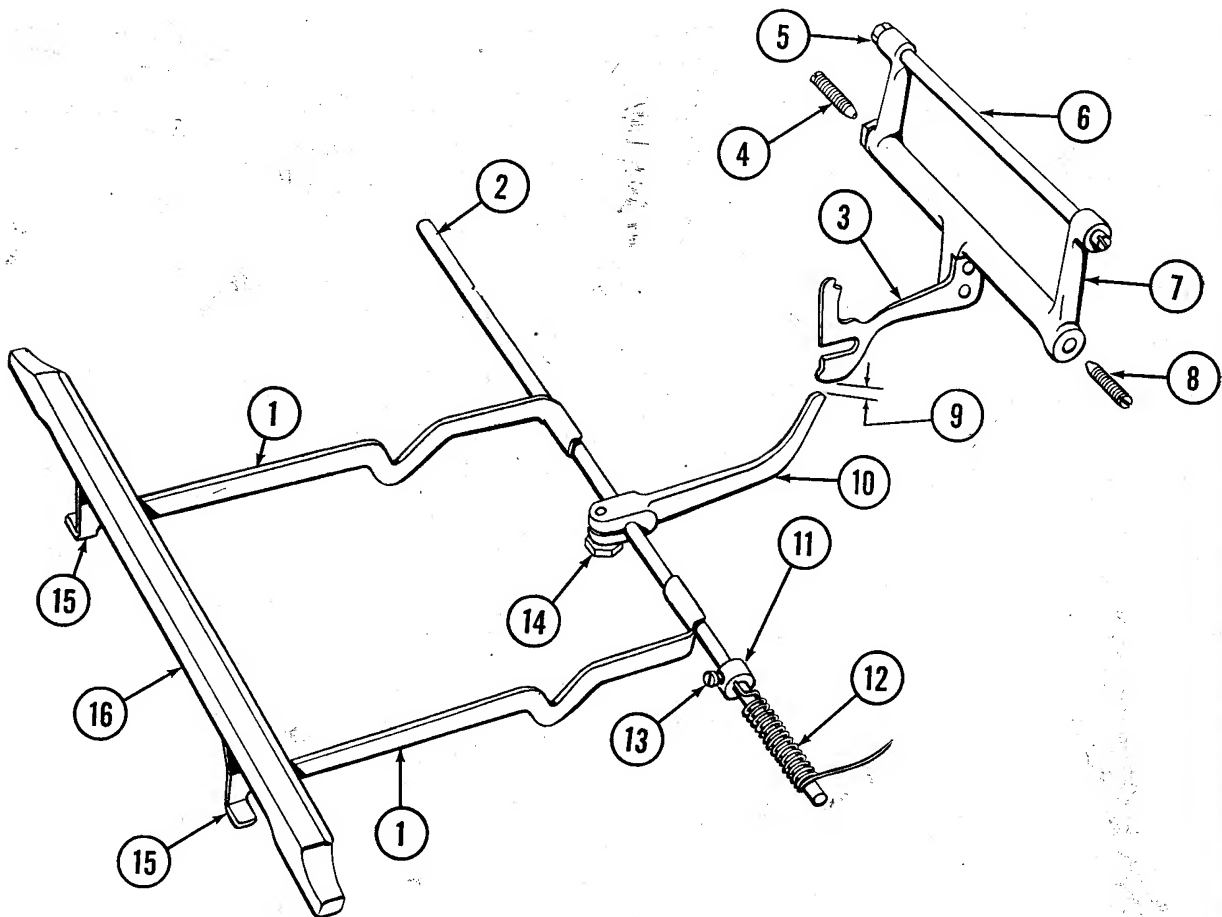

- 1 Spacebar frame lever
- 2 Space bar shaft
- 3 Rocker arm extension
- 4 Fulcrum pin
- 5 Nut
- 6 Universal bar shaft
- 7 Rocker arm
- 8 Fulcrum screw

- 9 Clearance of .010 to .020 inch
- 10 Spacebar adjusting lever
- 11 Spring adjusting collar
- 12 Spacebar spring
- 13 Spacebar spring adjusting collar lock screw
- 14 Adjusting lever screw
- 15 Spacebar stop
- 16 Spacebar

Figure 13 Spacebar mechanism.

rocker arm extension (3). To adjust, loosen spacebar adjusting lever screw (14), position adjusting lever (10), and tighten screw. Position lever to make a true contact with the rocker arm extension (3).

(6) *Final check.* To check spacebar adjust-

ments, depress and hold spacebar and check rocker to see that it has an additional movement of one-sixty-fourths of an inch. If adjustments to escapement and spacebar mechanisms have been made properly, the additional movement will be correct.

Section IX. BACKSPACE MECHANISM

30. General

The backspace mechanism (fig. 14) backs the carriage one space at a time to allow the operator to retype an impression. The mechanism consists of the backspace key lever assembly and backspace pawl carrier assembly.

31. Backspace Key Lever Assembly

a. Components. The backspace key lever assembly is composed of the key lever, shaft, shaft arm, and link.

b. Operation.

- (1) The backspace key lever (11, fig. 14) when depressed turns the key lever shaft (10) toward the front of the machine.
- (2) The shaft arm (8), fastened to the right end of the shaft, is forced down and pulls the link (5) down.

32. Backspace Pawl Carrier Assembly

a. Components. The backspace pawl carrier assembly is composed of the pawl carrier, carrier eccentric bushing, carrier spring, lever stud eccentric, and wheel lock.

b. Operation.

- (1) The backspace link pulls the pawl (17, fig. 14) toward the front of the machine, and at the same time the carrier spring (3) pushes the carrier (2) toward the front of the machine.
- (2) The carrier carries the pawl into engagement with the rack, and at the same time the wheel lock (1) moves under a tooth of the escapement wheel. When the carrier has moved as far as possible, the link continues to pull the pawl, which pivots toward the right of the machine.
- (3) The pawl pulls the rack toward the right of the machine until the pawl heel (15) contacts the pawl carrier washer (22).

33. Adjustments of Backspace Mechanism

The adjustments of the backspace mechanism must be made in sequence. Binds or lost movement anywhere in the backspace mechanism will cause the mechanism to operate improperly. Check and adjust carriage rack, if necessary, before making any adjustment to the backspace mechanism.

a. Backspace Key Lever. The backspace key lever (11) must rest lightly against the key lever stop (felt pad) in its normal position. To adjust, form key lever shaft arm (8) by using backspace bender.

b. Backspace Key Lever Shaft. The shaft (10, fig. 14) must turn freely. Check to see that shaft has proper pivot shoulder screws (6) and that bracket extensions (13) do not bind shaft. If necessary, form bracket extensions.

c. Backspace Link Spring. Form backspace link spring (7, fig. 14), if necessary, to make tension sufficient to return backspace mechanism to its normal position.

d. Backspace Pawl. The pitch of the backspace pawl (17, fig. 14) must correspond with the pitch of the rack. If the pawl is deformed, worn, or chipped, replace pawl. If pawl when engaged in rack teeth does not have a .003-inch clearance (fig. 15) from top of pawl to bottom of rack teeth, loosen backspace pawl carrier eccentric bushing setscrew (23, fig. 14) and turn eccentric bushing (24) to position pawl. Hold bushing and tighten lock screw. The carrier must position the pawl so that at least three-fourths of the pawl is in alignment with the rack teeth (fig. 16). To adjust, loosen stud eccentric setscrew (19, fig. 14) and turn eccentric to position pawl. Hold stud eccentric and tighten lock screw.

e. Backspace Pawl Carrier Spring. Form backspace pawl carrier spring (3, fig. 14), if necessary, to make tension sufficient to push carrier forward and engage pawl in rack teeth.

f. Wheel Lock. The heel of the wheel lock (1, fig. 14) must fit properly in the carrier slot. When in active position the heel must slip under escapement

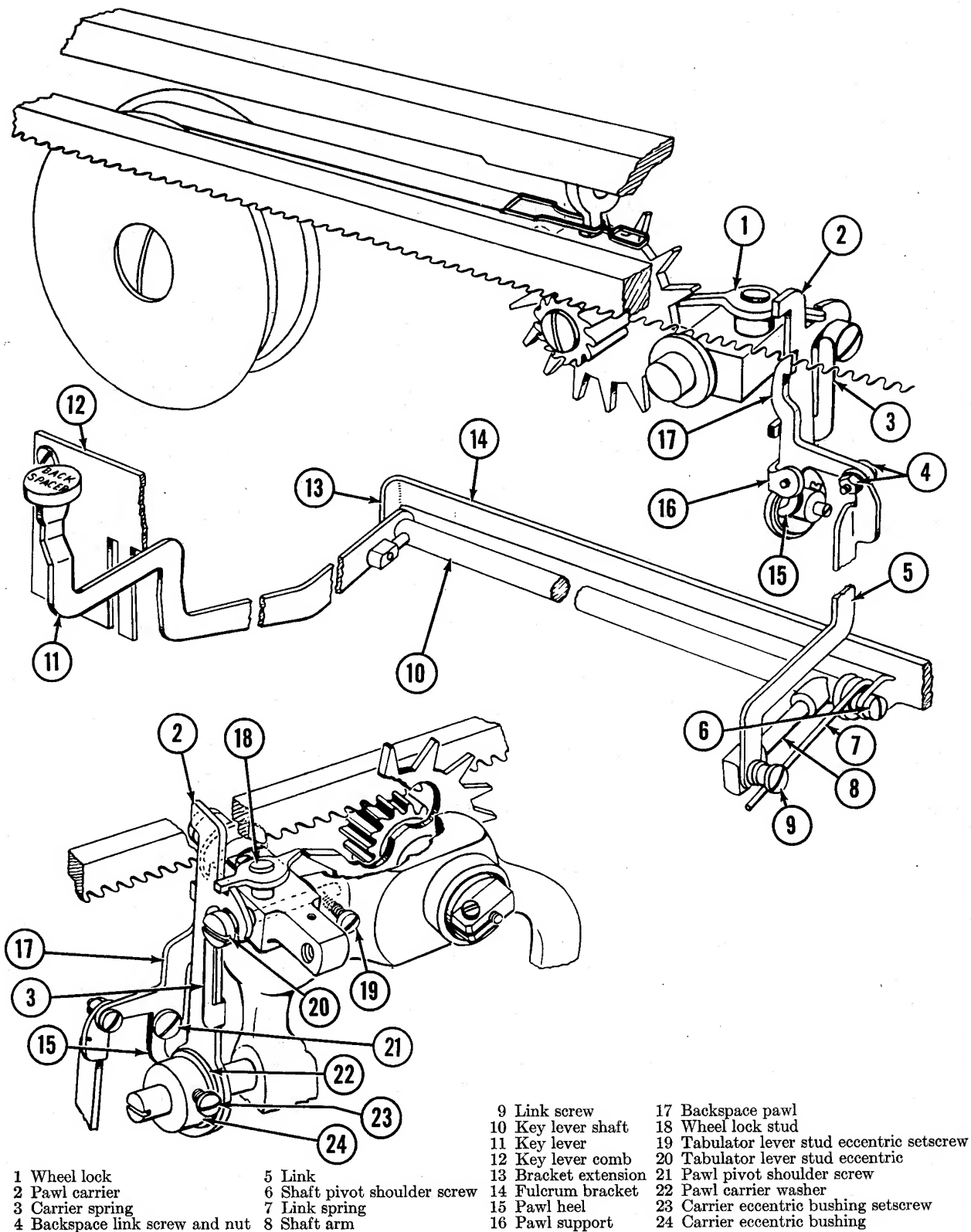

Figure 14. Backspace mechanism.

wheel tooth with the least possible clearance. To adjust, loosen wheel lock pivot stud lock screw and position pivot stud. Hold stud and tighten lock screw. Form lock if necessary.

g. Overthrow. If the carriage moves two or more spaces to the right when the backspace key lever is depressed, the mechanism is overthrowing. To adjust, loosen backspace pawl carrier eccentric bushing setscrew (23, fig. 14), remove bushing (24), and place pawl carrier washers (22) on rocker fulcrum pivot screw to stop pawl heel sooner and limit throw of pawl. Replace bushing and tighten lock screw. This adjustment may upset the .003-inch clearance between the pawl and rack. Readjust clearance if necessary.

h. Underthrow. If the carriage does not move a complete space when the backspace key lever (11, fig. 14) is depressed, the mechanism is underthrowing. To adjust, remove washers behind the bushing or form heel of pawl (15).

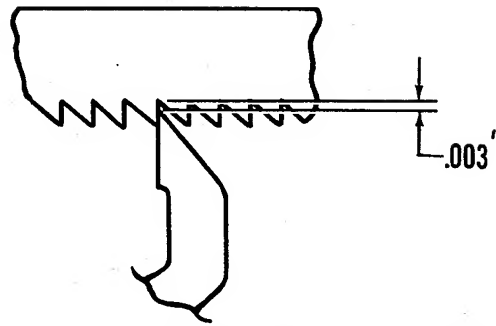

Figure 15. Diagram showing .003-inch clearance between top of backspace pawl and bottom of carriage rack teeth.

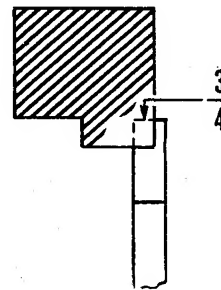

Figure 16. Diagram showing three-fourths of pawl in alignment with carriage rack teeth.

Section X. RIBBON FEED MECHANISM

34. General

The ribbon feed mechanism (fig. 17) feeds the ribbon from one spool to another to prevent the type from striking the same section of the ribbon each time the key lever is depressed. The ribbon feeds when typing and when depressing the spacebar. The ribbon feeds laterally from one spool to the other, the center of the ribbon passing freely through the ribbon guide. The ribbon feed is motivated by the rocker arm extension.

35. Ribbon Feed Actuating Shaft Assembly

a. Ribbon Feed Actuating Shaft Lever.

- (1) *Position.* The ribbon feed actuating shaft (21, fig. 17) must be secured to the shaft (22) so that the hub is turned toward the right and the lever end is centered in the slot of the rocker arm extension.
- (2) *Function.* The ribbon feed actuating shaft lever (21) when forced up and down by the rocker arm extension pivots the actuating shaft (22).
- (3) *Adjustment.* Loosen lever setscrew (20) and position lever in rocker arm extension. Hold lever and tighten setscrew.

b. Ribbon Feed Actuating Shaft.

- (1) *Position.* The actuating shaft is seated in the slots of the key lever bracket (23, fig. 17) and must have a .010- to .020-inch sideplay.
- (2) *Function.* The shaft, actuated by the shaft lever, pivots the feed pawl lever (32) and pulls the pawl down on the ribbon ratchet wheel (27). When the shaft is returned to its normal position, the pawl, seated in the ratchet wheel teeth, forces the wheel to turn.
- (3) *Adjustment.* To adjust shaft for proper sideplay, loosen ribbon feed actuating shaft lever setscrew (20) and shaft collar setscrew and position shaft collar. Hold shaft and tighten setscrew. Center shaft lever in rocker arm extension, hold lever, and tighten setscrew. The shaft retaining plates (19) must be secure on the key lever bracket (23), with the indented side toward the shaft.

36. Ribbon Feed Pawl Assembly

- a. *Position.* The ribbon feed pawl (18, fig. 17)

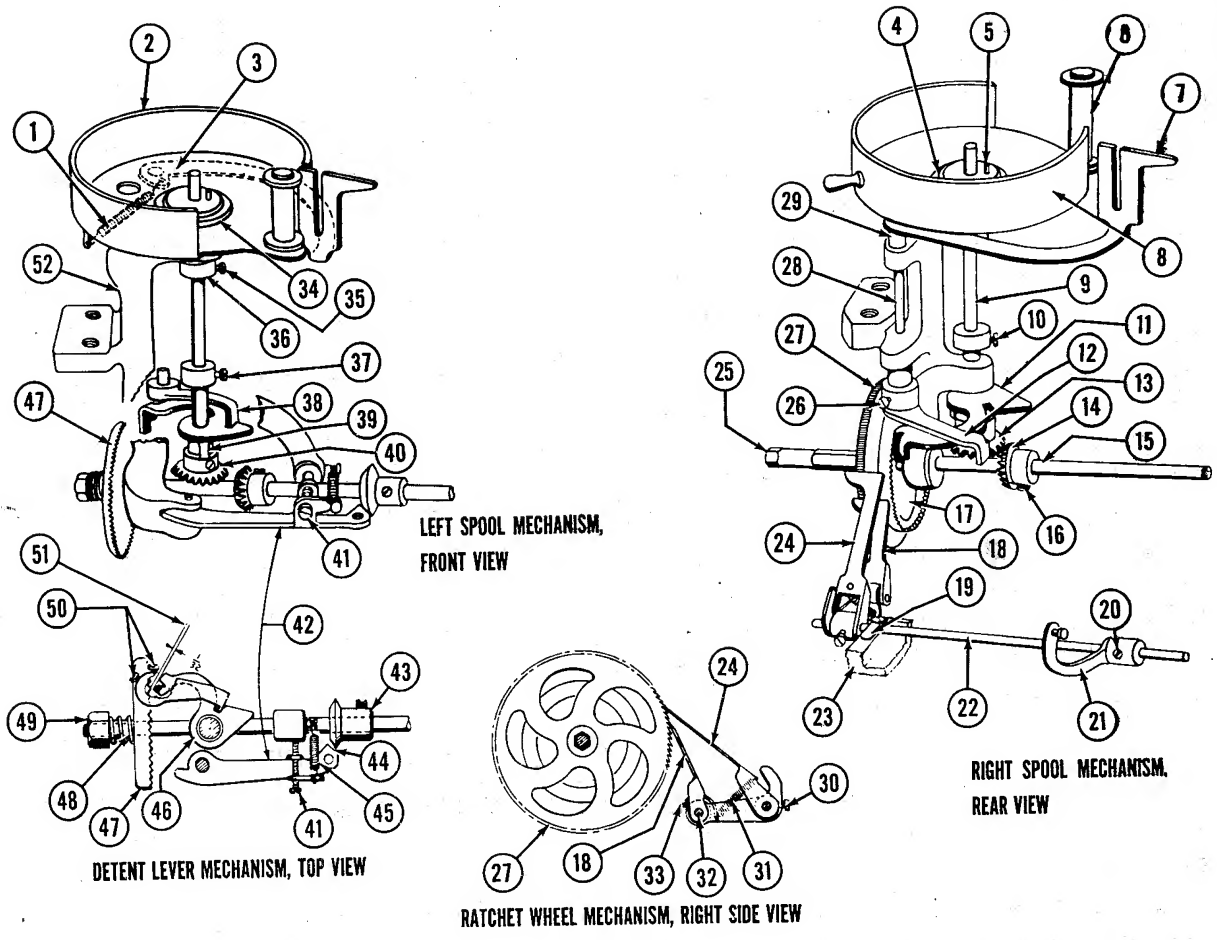

- | | |
|--|--|
| <ul style="list-style-type: none"> 1 Ribbon guard spring 2 Left ribbon spool guard 3 Left ribbon engaging lever 4 Right ribbon spool guard bushing 5 Ribbon spool pin 6 Ribbon guide rolls 7 Right ribbon engaging lever 8 Right ribbon spool guard 9 Right spool shaft 10 Right spool shaft bushing setscrew 11 Right ribbon shifting arm 12 Right ribbon shifting arm lock 13 Right spool shaft gear 14 Right drive shaft gear 15 Ribbon feed drive shaft 16 Feed drive shaft gear setscrew 17 Right shifting arm disk 18 Feed pawl 19 Actuating shaft retaining plate 20 Actuating shaft lever setscrew 21 Actuating shaft lever 22 Actuating shaft 23 Key lever bracket 24 Holding pawl 25 Ribbon feed shaft extension 26 Right shifting arm lock setscrew | <ul style="list-style-type: none"> 27 Ratchet wheel 28 Ribbon engaging lever shaft 29 Engaging lever shaft collar 30 Ribbon feed pawl lever binding screw 31 Pawl spring 32 Feed pawl lever 33 Ribbon feed pawl pin setscrew 34 Left ribbon spool guard bushing 35 Spool shaft collar setscrew 36 Spool shaft collar 37 Left spool shaft bushing setscrew 38 Left shifting arm lock 39 Spool shaft spring 40 Spool shaft gear 41 Detent lever adjusting screw 42 Detent lever 43 Detent collar 44 Clearance, $\frac{1}{4}$ inch 45 Detent lever tension spring 46 Left shifting arm 47 Left shifting arm disk 48 Shifting arm disk spring 49 Shifting arm disk nut 50 Left ribbon shifting arm lock setscrews 51 Clearance, $\frac{1}{32}$ inch 52 Spool bracket |
|--|--|

Figure 17. Ribbon feed and ribbon reverse.

must be secured on the shaft and centered on the ribbon feed ratchet wheel (27). The feed pawl and holding pawl (24) must be $3\frac{1}{2}$ teeth apart.

b. *Function.* When the shaft pivots the feed pawl lever, the lever moves the feed pawl down on the ribbon ratchet wheel. The holding pawl engages the teeth of the ratchet wheel and holds the wheel while the feed pawl is reseating. The wheel will backlash slightly until the holding pawl is seated.

c. *Adjustments.* Loosen ribbon feed pawl lever binding screw (30, fig. 17) and position pawl assembly on shaft so that pawls will be centered on ratchet wheel. Hold assembly and tighten screw. The pawl spring (31) must be hooked from the holding pawl to the feed pawl, as shown in figure 17, and must have sufficient tension to keep pawls engaged in ratchet wheel. To adjust for the $3\frac{1}{2}$ -tooth clearance between the two pawls, loosen ribbon feed pawl lever binding screw and position feed pawl up or down until required position is obtained. Hold pawl and tighten screw.

37. Ribbon Feed Drive Shaft Assembly

a. Ratchet Wheel.

- (1) *Position.* The ratchet wheel (27, fig. 17) is attached to the end of the drive shaft (15) by the drive shaft extension.
- (2) *Function.* The ratchet wheel transfers the power from the feed pawl to the drive shaft.
- (3) *Adjustment.* If ratchet wheel teeth are worn or chipped, replace wheel.

b. Ribbon Feed Drive Shaft.

- (1) *Position.* The drive shaft (15, fig. 17) is fitted through the bottom of the ribbon spool bracket (52) and is held in position by the ribbon shifting arm disk (47) on the left and by the ratchet wheel and ribbon shifting arm disk (17) on the right.
- (2) *Function.* The ribbon drive shaft supports the drive shaft gears, shifting arm disk, detent collar, and ratchet wheel.
- (3) *Adjustment.* Replace shaft if shaft is deformed.

c. Ribbon Feed Drive Shaft Gears.

- (1) *Position.* The ribbon feed drive shaft gears (14, fig. 17) are secured to the shaft by a setscrew (16) in each gear. When in active position, the gears mesh in the spool shaft gears (13) as deeply as possible without bottoming.

- (2) *Function.* The drive shaft gears transfer the power of the drive shaft to the spool shaft (9).
- (3) *Adjustment.* Place drive shaft in active position for drive shaft gear that is to be adjusted. Loosen gear setscrew, position gear so that it meshes properly with spool shaft gear, and tighten setscrew.

38. Spool Shaft Assembly

a. Ribbon Spool Shaft Gears.

- (1) *Position.* The ribbon spool shaft gears (13 and 40) are located on the lower end of the shafts and are positioned flush with the lower end of the shafts.
- (2) *Function.* The shaft gears transfer the power of the drive shaft to the spool shafts.
- (3) *Adjustment.* Loosen ribbon spool shaft gear setscrew and position gear flush with bottom of shaft. Hold gear and tighten setscrew.

b. Ribbon Spool Shafts.

- (1) *Position.* The ribbon spool shafts run vertically through the ribbon spool bracket and must have .010-inch up-and-down play. The proper position is controlled by the ribbon spool shaft collar (36).
- (2) *Function.* The shafts turn the ribbon spools and wind the ribbon from one spool to the other.
- (3) *Adjustment.* To adjust for the proper up-and-down play, loosen ribbon spool shaft collar setscrew (35), hold shaft down, and position collar so that there is .010-inch clearance between top of collar and bottom side of ribbon bracket. Hold collar and tighten setscrew.

c. Ribbon Spool Guard Bushings.

- (1) *Position.* The ribbon spool guard bushings (34) fit into the top of the spool bracket and are held secure by a setscrew in each bracket.
- (2) *Function.* The spool bushings support the upper end of the spool shafts and hold the spool guards (2) in proper position.
- (3) *Adjustment.* To allow the spool guards to pivot, loosen bushing setscrew, position bushing up or down for proper freedom of guard, and tighten setscrew.

39. Spool Assembly

a. Ribbon Spool Guards.

- (1) *Position.* The ribbon spool guards (2) are held on the top of the spool brackets by the spool bushings.
- (2) *Function.* The ribbon spool guards prevent the ribbon from slacking and winding around bracket.
- (3) *Adjustment.* To adjust the ribbon spool guards, adjust the ribbon spool guard bushings as described in paragraph 38c(3). The ribbon guard springs must have sufficient

tension to return guards with a snappy action. Replace ribbon spool guards if guide rolls (6) bind.

b. Ribbon Spools.

- (1) *Position.* The ribbon spools fit over the end of the shaft. The holes around the hub of the spool fit over the spool pin (5).
- (2) *Function.* The spools feed and collect the ribbon when it is wound from one spool to the other.
- (3) *Adjustment.* Replace spool when any malfunction occurs in the spool.

Section XI. RIBBON REVERSE

40. General

The ribbon reverse mechanism reverses the direction of the ribbon feed by either the manual or the automatic reverse.

41. Manual Reverse

The manual reverse consists of the following parts:

a. Ribbon Winding Handle.

- (1) *Position.* The ribbon winding handle is fastened to the drive shaft by a spring washer and a binding screw screwed into the end of the ribbon feed shaft extension (25, fig. 17).
- (2) *Function.* The winding handle is used to wind ribbon from one spool to the other manually and also to reverse the ribbon.

b. Drive Shaft.

- (1) *Position.* The ribbon feed drive shaft (15, fig. 17) is fitted through the bottom of the ribbon spool bracket (52) and is held in position by the left ribbon shifting arm disk (47) on the left and the ratchet wheel and shifting disk on the right.
- (2) *Function.* The drive shaft, when pushed to the left, moves the left drive shaft gear in mesh with the shaft gear of the left spool shaft. When pulled to the right, it moves the right drive shaft gear in mesh with the shaft gear of the right spool shaft.
- (3) *Adjustment.* If necessary, adjust the drive shaft gears as described in paragraph 37c(3).

c. Detent Collar.

- (1) *Position.* The ribbon detent collar (43,

fig. 17) is placed on the shaft with the hub to the right and held secure by a setscrew. The collar must be positioned so there is $\frac{1}{64}$ -inch clearance (44) between the collar and the detent lever (42).

- (2) *Function.* The detent collar is held to the right or left by the detent lever and thus holds the drive shaft gear in mesh with the spool shaft gear.
- (3) *Adjustment.* Loosen detent collar setscrew and position collar so that there is $\frac{1}{64}$ -inch clearance between detent and detent lever. Hold collar and tighten setscrew.

d. Ribbon Detent Lever.

- (1) *Position.* The detent lever (42, fig. 17) is fastened to the spool bracket (52) by a pivot screw and is positioned $\frac{1}{64}$ inch from the reverse detent. It is held in position by an adjusting screw and tension spring.
- (2) *Function.* The detent lever holds the detent collar to either the left or right and therefore holds the drive shaft gears in mesh with either the left or right spool shaft gear.
- (3) *Adjustment.* If the $\frac{1}{64}$ -inch clearance cannot be obtained by adjusting the detent collar, adjust the detent lever by turning the detent lever adjusting screw (41) clockwise or counterclockwise as necessary. Be sure the detent lever tension spring (45) has enough tension to keep the adjusting screw against the ribbon bracket.

42. Automatic Reverse

The automatic reverse consists of the following parts:

a. Ribbon Engaging Levers.

- (1) *Position.* The ribbon engaging levers (3 and 7, fig. 17) are fitted to the tops of the ribbon engaging lever shafts and are held forward against the spool brackets by tension springs.
- (2) *Function.* The engaging levers when forced rearward by the ribbon eyelets actuate the engaging lever shafts.
- (3) *Adjustment.* The ribbon engaging lever slot should be $\frac{1}{16}$ inch wide. Adjust by forming. The lever must have $\frac{1}{64}$ -inch up-and-down movement. Loosen ribbon shifting arm lock setscrews (50) and position lock to obtain proper movement. Hold lock and tighten setscrews.

b. Engaging Lever Shaft.

- (1) *Position.* The engaging lever shaft (28, fig. 17) extends through the spool bracket. It must have $\frac{1}{64}$ -inch up-and-down play.
- (2) *Function.* The engaging lever shaft supports and actuates the shifting arm lock.
- (3) *Adjustment.* Adjust for $\frac{1}{64}$ -inch up-and-down movement as described in a(3) above.

c. Shifting Arm Locks.

- (1) *Position.* The shifting arm locks (12 and 38, fig. 17) are fastened to the ends of the engaging lever shafts by two setscrews in each lock. The locks must be flush with the ends of the shifting arm slots.
- (2) *Function.* The shifting arm locks return and hold the shifting arms (11 and 46) in their normal position.
- (3) *Adjustment.* To adjust lock for position, loosen shifting arm lock setscrews (26 and 50), hold engaging lever lightly against

guide roll (6), and position shifting arm lock properly. Hold lock and tighten setscrews.

d. Ribbon Shifting Arms.

- (1) *Position.* The ribbon shifting arms (11 and 46, fig. 17) slide onto the spool shafts. The arms must clear the shifting arm disks by one-thirty-seconds of an inch when inactive and must have .005- to .010-inch up-and-down play.
- (2) *Function.* The shifting arms, when released by the arm locks, are forced by spring tension from the spool shaft springs (39) to pivot with the shaft. The arms contact the shifting arm disks (17 and 47) and kick them outward.
- (3) *Adjustment.* To adjust for proper clearance of one-thirty-seconds of an inch (51) between the shifting arm and disk, make all previous ribbon feed and reverse adjustments. Loosen ribbon spool shaft bushing setscrews, hold down on shaft, and position shaft bushing to allow for proper up-and-down play. Hold shaft and bushing and tighten setscrew.

e. Shifting Arm Disks.

- (1) *Position.* The left shifting arm disk (47, fig. 17) is fastened to the left end of the drive shaft by the disk spring (48) and nut (49). The right shifting arm disk (17) is sweated to the ribbon ratchet wheel and fastened to right end of the drive shaft by the shaft extension.
- (2) *Function.* The disk pulls the drive shaft, moving the drive shaft gears from side to side out of engagement with one spool shaft gear and in engagement with the other.

Section XII. RIBBON COVER MECHANISM

43. General

The ribbon cover mechanism (fig. 18) controls the up-and-down movement of the ribbon to cover the typeface. The mechanism may be set in black, red, or stencil position. In the black position, the upper half of the ribbon is raised to cover the typeface; in the red position, the lower half of the ribbon is raised to cover the typeface; and in the stencil position, the ribbon does not rise at all but remains retracted so that the typeface strikes directly against the stencil.

44. General Adjustments

Before attempting any adjustment to the ribbon cover mechanism, check ribbon to see that, with sub-carriage in nonshift position, the tip of the ribbon is one-tenth of an inch above type guide. To adjust, use T-bender and form the lower ribbon guide actuating lever (20, fig. 18) up or down as necessary.

45. Components

a. Ribbon Guide.

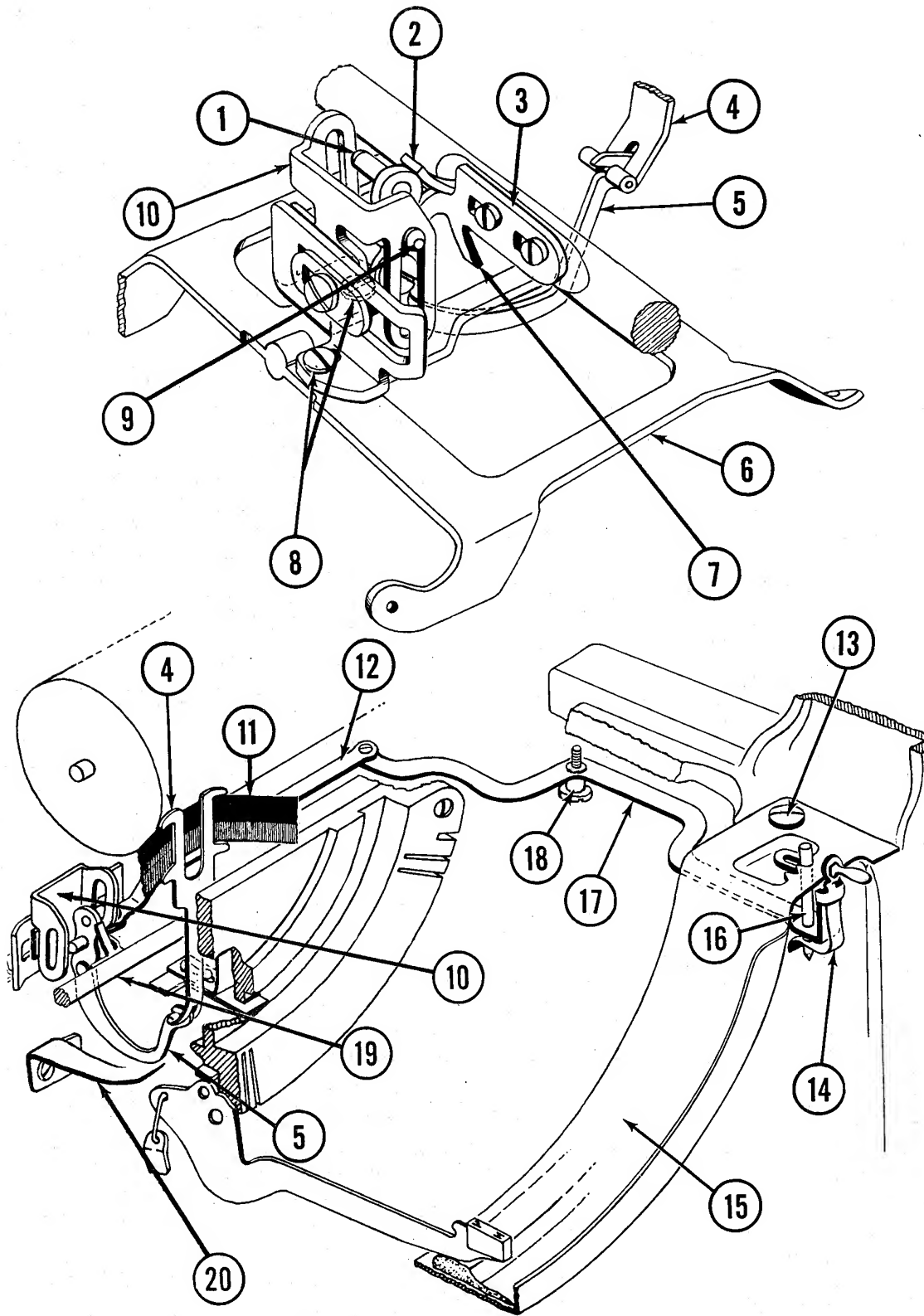

Figure 18. Ribbon cover.

- | | |
|---|--|
| 1 Actuating lever stud (upper) | 11 Ribbon |
| 2 Ribbon guide actuating lever bracket stop (upper) | 12 Ribbon shift slide link |
| 3 Ribbon guide actuating lever bracket | 13 Type bar nest binding screw |
| 4 Ribbon guide | 14 Detent pin spring |
| 5 Actuating lever | 15 Type bar nest |
| 6 Universal bar | 16 Detent pin |
| 7 Ribbon guide actuating lever bracket stop (lower) | 17 Ribbon shift lever |
| 8 Ribbon shift slide bracket binding screws | 18 Ribbon shift lever pivot screw |
| 9 Actuating lever stud (lower) | 19 Lift frame rail |
| 10 Ribbon shift slide | 20 Ribbon guide actuating lever stop (lower) |

Figure 18. Ribbon cover—Continued

- (1) *Position.* The ribbon guide (4, fig. 18) is fastened to the end of the actuating lever (5) and travels vertically against the type guide.
 - (2) *Function.* The ribbon guide controls the up-and-down movement of the ribbon to cover the typeface. The guide is forced up and down by the actuating lever.
 - (3) *Adjustment.* Form guide when necessary to insure a snug fit.
- b. *Ribbon Guide Guard.*
- (1) *Position.* The ribbon guide guard is fastened on top of the segment behind the ribbon guide by two binding screws.
 - (2) *Function.* The guide guard supports the guide and prevents it from becoming malformed.
 - (3) *Adjustment.* To allow freedom of the guide, loosen guide guard setscrews and position guard. Hold guard and tighten setscrews.
- c. *Ribbon Shift Lever Detent Pin Spring.*
- (1) *Position.* The ribbon shift lever detent pin spring (14, fig. 18) is fastened to the ribbon shift lever (17) by a binding screw through the lever handle. The lower end of the spring fits into a slot in the detent pin.
 - (2) *Function.* The pin spring supplies sufficient tension to the pin to hold the lever handle in the black, red, or stencil position where it has been placed.
 - (3) *Adjustment.* To adjust, position type bar nest.
- d. *Ribbon Guide Actuating Lever Bracket.*
- (1) *Position.* The ribbon guide actuating lever bracket (3, fig. 18) is fastened to the lift frame rail (19) by two binding screws. The bracket must be positioned so that when the ribbon shift lever is in the stencil position the actuating lever studs (1 and 9) are centered in the ribbon shift slide (10).
 - (2) *Function.* The lever bracket serves as a pivot point for the actuating lever.
 - (3) *Adjustment.* To adjust, place ribbon shift lever (17) in stencil position, loosen bracket binding screws, and position bracket so that studs are centered in ribbon slide. Hold bracket and tighten screws.
- e. *Ribbon Guide Actuating Lever Bracket Stops.*
- (1) *Position.* The lever bracket stops are a part of the lever bracket. The upper stop (2, fig. 18) should be positioned so that it limits the actuating lever when the studs are alined with slots in the ribbon shift slide. The lower stop (7) should be positioned so that it limits the movement of the actuating lever and thus prevents the lever from raising the ribbon too high (in red position *only*).
 - (2) *Function.* The upper stop (2) keeps the actuating lever studs alined with slots in the ribbon slide. The lower stop (7) prevents the actuating lever from throwing the ribbon too high (in red position).
 - (3) *Adjustment.* To adjust, form the stops as necessary.
- f. *Ribbon Shift Slide.*
- (1) *Position.* The ribbon shift slide (10, fig. 18) is fastened to the shift slide bracket by a binding screw and a slide shoe. The bracket is fastened to the universal bar by two binding screws (8). The shift slide must be positioned so that when the ribbon shift is in the stencil position the slide does not intercept either of the actuating lever studs. When the ribbon shift is in the red or black position, either the left or the right stud will engage the slide while the opposite stud is left free.
 - (2) *Function.* When engaged by a stud (1 or 9), the slide will apply force to the stud and pivot the actuating lever (5). Therefore the

slide controls the movement of the lever and the ribbon.

- (3) *Adjustment.* To adjust, loosen shift slide binding screw and operate ribbon shift lever

back and forth to aline itself. Tighten screw. There should be no movement of the ribbon guide (4) when lever is shifted.

Section XIII. MARGIN MECHANISM

46. General

The margin mechanism (fig. 19) allows the operator to obtain an even margin on the typing paper.

47. Right Marginal Stop Assembly

a. Function. The right marginal stop assembly controls the left margin on the paper.

b. Components. The stop assembly is composed of the marginal stop, stop release lever, carriage frame pointer, front scale, front stop rod (large), front stop rod (small), and carriage frame stop.

c. Operation. The right marginal stop (10, fig. 19) fits on the large and small stop rods. The stop is moved left and right on the rods by depressing the stop lever (11) to disengage the teeth of the lever from the teeth of the large rod (12). When the teeth have been disengaged, the stop may be moved to the desired margin position. As the carriage moves to the right, the left end of the marginal stop release lever (8) contacts the protrusion on the back side of the stop and stops the movement of the carriage. The margin is released by depressing the marginal stop release lever. When the carriage is released, it may be moved to the extreme right until it is stopped by the carriage frame stop (13, fig. 2). The graduations on the front scale (1, fig. 2) correspond with the spaces on the typing paper. The marginal stop pointer (42, fig. 19) must point to the corresponding number on the front scale and aline with the carriage frame pointer (7) when the carriage is at its left margin.

d. Adjustments. When carriage stops beyond set margin, the margin is overthrowing; when carriage stops short of set margin, the margin is banking. To correct overthrowing, add washers on left end of large marginal stop rod (12, fig. 19); to correct banking, remove washers from end of rod. To gain access to rod, remove right binding screw and push rod to left. After adding or removing washers, as necessary, replace rod and tighten binding screw. Adjustments to the following parts of the margin mechanism may be necessary to correct overthrowing and banking.

- (1) *Carriage frame pointer.* The carriage frame

pointer (7, fig. 19) is attached to the main carriage frame. The pointer must aline with the graduations on the front scale. To adjust, loosen front scale plate screws and position scale plate to extreme left. Hold plate and tighten screws. Loosen front scale screws and position scale to aline graduations with frame pointer. Hold scale and tighten screws. Do not form carriage frame pointer.

- (2) *Right marginal stop pointer.* The right marginal stop pointer is fastened to the stop by the stop knob (27). The pointer must aline with graduations on the front scale. To adjust, loosen marginal stop knob, position pointer, and tighten knob. To obtain proper zero position, move right marginal stop (10) to extreme right, loosen right marginal stop rod collar setscrew, and position collar (43) so that pointer alines with zero graduation. Hold collar and tighten setscrew.
- (3) *Marginal stop release lever.* The release lever spring (9) must have sufficient tension to return the lever with a snappy action. If the spring has too much tension, it will cause the release lever to push the stop to the left when typing beyond the margin. To adjust, form spring. When the marginal stop release lever is in its normal position, three-thirty-seconds of an inch of the left end will contact the marginal stop protrusion. To adjust, place on bench block and form.
- (4) *Marginal stop rods.* The marginal stop rods (12 and 13) must be clean, straight, and lightly lubricated. To lubricate, wipe with oily cloth.
- (5) *Right marginal stop lever (11).* The marginal stop lever spring must have sufficient tension to return and hold the lever teeth in mesh with the large marginal stop rod (12). Adjust tension by clipping or stretching spring as necessary.
- (6) *Right marginal stop lever handle.* The stop

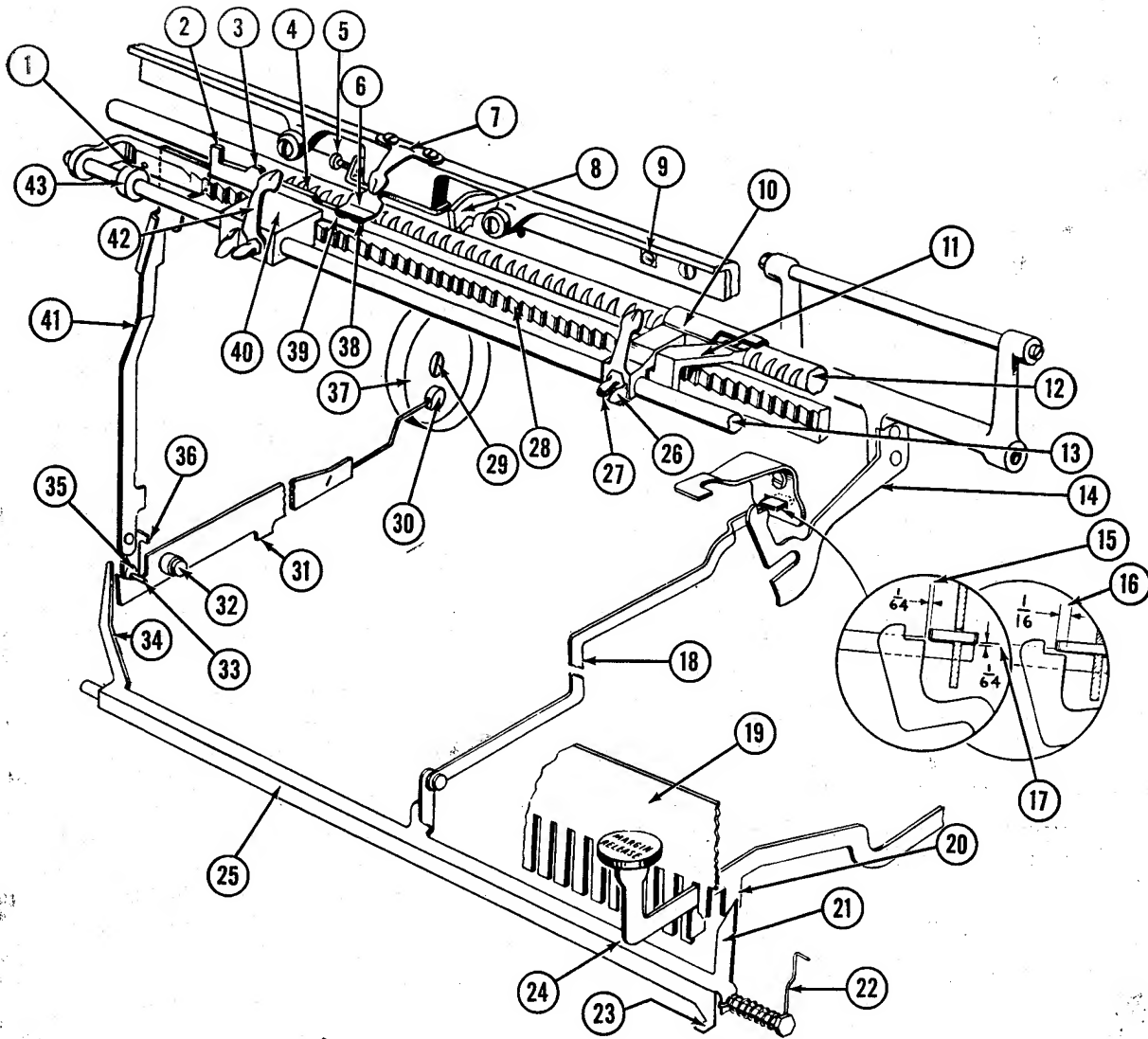

- | | |
|---|-------------------------------------|
| 1 Left marginal stop rod collar setscrew | 22 Lock slide spring |
| 2 Upright end of marginal stop | 23 Lock slide stop |
| 3 First step of marginal stop | 24 Margin release key lever |
| 4 High point of marginal stop | 25 Key lever lock slide |
| 5 Trip adjuster adjusting screw | 26 Right marginal stop lever handle |
| 6 Bell trip adjuster | 27 Right marginal stop knob |
| 7 Carriage frame pointer | 28 Bell rack frame |
| 8 Marginal stop release lever | 29 Bell screw |
| 9 Release lever spring | 30 Bell hammer |
| 10 Right marginal stop | 31 Bell lever hammer |
| 11 Right marginal stop lever | 32 Bell lever hammer pivot stud |
| 12 Marginal stop rod (large) | 33 Lever toggle pin |
| 13 Marginal stop rod (small) | 34 Lock slide arm |
| 14 Rocker arm extension | 35 Lever toggle |
| 15 Clearance in normal position | 36 Toggle stop |
| 16 Lip overlap of $\frac{1}{16}$ inch | 37 Bell |
| 17 Clearance from lip to bottom of cutout with lip in active position | 38 Second camshape |
| 18 Key lever lock slide link | 39 First camshape |
| 19 Key lever comb | 40 Left marginal stop |
| 20 Margin release key lever extension | 41 Bell rack frame lever |
| 21 Lock slide extension | 42 Marginal stop pointer |
| | 43 Left marginal stop rod collar |

Figure 19. Marginal stops and line locks.

lever handle (26) must have sufficient movement to disengage the lever from the rod. To adjust, form lever as necessary.

- (7) *Backlash pawl.* The backlash pawl is not a part of the marginal stops, but its function is a part of the marginal stop operation. The backlash pawl prevents the escapement wheel from turning when the carriage is being returned. This allows the pinion pawl to be in position to engage the pinion teeth when the carriage is released. The pawl spring must have sufficient tension to return and hold the pawl in its normal position against the hub in which the trip adjusting screw is fitted. To adjust, form spring.
- (8) *Carriage frame stop.* The carriage frame stop (13, fig. 2) is filed to obtain the zero position of the carriage. When the carriage is to the extreme right, the left end of the marginal stop release lever must be .001 inch from the carriage frame stop. Replace carriage frame stop if it is too short.

48. Left Marginal Stop Assembly

a. *General.* The left marginal stop assembly controls the right margin on the paper and the line lock.

b. *Components.* The mechanism is composed of the left marginal stop (40, fig. 19), bell trip adjuster (6), bell rack frame (28), bell rack frame lever (41) and toggle (35), bell rack frame spring, bell lever hammer (31), bell (37), key lever lock slide (25), key lever lock slide spring (22), margin release key lever (24), and margin release key lever tension spring.

c. *Operation.*

- (1) *First line lock.* The left marginal stop (40, fig. 19) fits on the small stop rod and the bell rack frame (28). The stop is moved left and right on the rods by depressing the stop lever to disengage the teeth of the lever from the teeth of the bell rack frame. When the teeth have been disengaged, the stop may be moved to the desired margin position. When the carriage moves space by space to the left, the first camshape (39) of the bell trip adjuster contacts the incline of the marginal stop and, as it continues to move, depresses the stop. The stop fitted to the bell rack frame (28) forces the frame downward. The bell rack frame lever (41), attached to the left end of the bell rack frame, swings toward the front of the ma-

chine. The lever toggle pin (33) moves out of the notch in the bell lever hammer (31), trips the hammer, and creates a bell ring. After the bell ring, the carriage continues to move the bell trip adjuster to the left. The first camshape (39) continues up the incline and mounts the high point of the marginal stop. The stop is depressed farther down and causes the frame lever and toggle to move forward. Seven spaces after the bell ring, the first camshape of the bell trip adjuster contacts the first step (3) of the marginal stop and depresses the stop fully. The toggle pin contacts and pivots the lock slide arm (34). The lock slide arm pivots the lock slide, and the lock slide pulls the key lever lock link (18) toward the front of the machine. The rear end of the link moves forward into the cutout of the rocker arm extension (14). While in this position, the link locks the rocker arm extension and prevents the carriage from moving and the type bar from striking the cylinder.

- (2) *Margin release.* Before typing can be continued, the margin must be released. The margin is released by depressing the margin release key lever (24). The key lever extension (20) contacts the lock slide beveled extension (21) and forces the lock slide to the right, and the lock slide arm moves out of engagement with the toggle pin (33). When the key lever is released, the lock slide spring (22) pivots the lock slide to the rear and returns it to the left. The lock slide arm has then moved back into alignment with the toggle pin, but is positioned behind the pin. The line lock is released and typing may be continued.
- (3) *Second line lock.* After the first line lock is released and typing is resumed, the carriage continues to move the bell trip adjuster (6) to the left. The first camshape (39) of the trip adjuster slips off the first step of the marginal stop and releases the marginal stop to move upward. The upward movement of the stop moves the bell rack frame lever (41) to the rear and flips the toggle pin (33) over behind the slide arm (34). Four spaces after the first line lock is released, the second camshape (38) of the bell trip adjuster contacts the first step (3) of the marginal stop and forces the marginal stop downward to create a second line lock.

- (4) *Third line lock.* Before typing may be resumed, the margin must be released as described in (2) above. After the line lock is released, the carriage can move only a little more than one-third of a space. The bell trip adjuster (6) contacts the upright end of the marginal stop (2) and stops the movement of the carriage. The escapement wheel stops with a tooth directly behind the rigid dog. The escapement wheel tooth stops the rigid dog, locks the escapement mechanism, and creates a third line lock.

d. *Adjustments.* Adjustments made to the marginal stop and line lock assembly must be made with extreme care in the sequence in which they are given below.

- (1) *Left marginal stop.* Check stop. If any part shows excessive wear or burrs, replace the marginal stop.
- (2) *Left marginal stop lever spring.* If marginal stop lever spring has not sufficient tension to return and hold teeth of lever in mesh with teeth of bell rack frame, stretch or shorten spring as necessary.
- (3) *Left marginal stop lever handle.* If stop lever handle has not sufficient movement to disengage lever from bell rack frame, form lever as necessary.
- (4) *Left marginal stop pointer.* The left marginal stop pointer (42, fig. 19) is fastened to the marginal stop by the marginal stop knob. If pointer does not align with graduations on front scale, loosen knob, position pointer, and tighten knob.
- (5) *Left marginal stop rod collar.* The left marginal stop rod collar (43) limits the left marginal stop (40). The stop rod collar must be positioned so that when the left marginal stop is against the collar, the stop pointer (42) is 5 spaces from the end of the scale and the teeth of the lever are engaged in the teeth of the bell rack frame (28). To adjust, loosen left marginal stop rod collar setscrew (1), position collar and stop, and tighten setscrew. Have screws on collar to the back of the machine.
- (6) *Bell rack frame.* If bell rack frame has more than .005-inch sideplay, loosen bell rack frame collar setscrew, position collar for proper sideplay, and tighten setscrew.
- (7) *Third line lock.* When the bell trip adjuster

(6) contacts the upright end of the left marginal stop (40), the escapement wheel tooth must be directly behind the rigid dog. To adjust, loosen the two bell trip adjuster holding screws and position bell trip adjuster by turning trip adjuster adjusting screw (5) clockwise or counterclockwise as necessary. Hold trip adjuster and tighten screws. Have trip adjuster screws friction tight.

- (8) *Bell ring.* When the first camshape (39) of the bell trip adjuster is just short of the high point of the marginal stop, the bell must ring and the carriage frame pointer (7) must be positioned 7 spaces from the left marginal stop pointer (42). In order to regulate the bell ring, the following adjustments are made in sequence.

(a) *Bell rack frame lever and toggle.* If frame lever toggle (35) is not straight with pin centered in notch of lever hammer without bottoming, loosen the two frame lever binding screws, position lever, and tighten screws for depth adjustment. At the same time check key lever lock slide arm (34) alignment with toggle pin (33).

(b) *Bell lever hammer and bell hammer.* If bell lever hammer (31) does not pivot freely on its pivot stud (32), loosen bell lever hammer pivot stud setscrew and position pivot stud. Hold stud and tighten setscrew. If bell hammer does not slightly clear bell, form bell hammer wire as necessary.

(c) *Bell trip adjuster.* If bell trip adjuster (6) does not overlap marginal stop incline three-thirty-seconds of an inch before contact is made, form adjuster up or down as necessary.

- (9) *First line lock.* When the first camshape (39) of the bell trip adjuster contacts the first step (3) of the marginal stop, the first line lock must take place and the carriage frame pointer (7) must be aligned with the left marginal stop pointer (42). To regulate the first line lock, the following adjustments are made in sequence:

(a) *Key lever lock slide.* If key lever lock slide spring (22) does not have sufficient tension to return the slide to its inactive position, coil spring toward front of machine. To adjust for less tension,

uncoil spring toward rear of machine. Be sure key lever lock slide is free.

- (b) *Key lever lock slide link.* If lip of key lever lock slide link (18) in its inactive position does not clear rocker arm extension (14) by one-sixty-fourth of an inch, form link lip toward front or rear of machine as necessary. If lip of link in its active position does not clear cutout of rocker arm extension by one-sixty-fourth of an inch (17), loosen ribbon guide actuating lever binding screws, position stop for proper clearance, and tighten screws. When the link is pulled forward to the active position, the lip must overlap the cutout of the rocker arm extension one-sixteenth of an inch (16). To adjust, form key lever lock slide arm (34) toward the front of the machine or toward the rear as necessary.

(10) *Margin release.* When the margin release key lever (24) is depressed, the key lever lock slide arm (34) is forced to the right, releasing the toggle pin (33) and thus allowing the key lever lock slide (25) to return to its normal position. Form the margin release key lever extension (20) if more throw is needed.

- (11) *Second line lock.* When the second cam-shape (38) of the bell trip adjuster contacts the first step (3) of the marginal stop, the second line lock must take place and the carriage frame pointer (7) must be 4 spaces from the left marginal stop pointer (42). The second line lock adjustment is made only after all previous adjustments have been made. To adjust, form second cam-shape (38) of bell trip adjuster (6).

Section XIV. TABULATOR MECHANISM

49. General

The key set tabulator mechanism allows the operator to move the carriage and position the paper to preset spacing. It aids the operator in indenting and column writing. The tabulator mechanism consists of four assemblies.

50. Key Set Tabulator Stop-Setting Assembly

a. Components. The key set tabulator stop-setting assembly (fig. 20) is composed of the set key lever, key lever stop, stop-setting plunger, rocker lever, stop-setting link, and link lever.

b. Function. The key set tabulator stop-setting assembly is designed to enable the operator to set the stops by positioning the carriage to the desired position and pushing the tabulator stop set key.

c. Operation. The set key lever (19, fig. 20) pivots on a fulcrum rod (18) fitted through the escapement frame. It extends from the keyboard to the rear of the machine, with the rear end engaged in a slot in the tabulator housing. When depressed, the rear end of the key lever forces the stop-setting plunger (16) up and pivots the rocker lever (14). The rocker lever pulls down on the stop-setting link (10), which pushes the tabulator stop (9) into the active position. The link lever (11) supports the upper end of the stop-

setting link. The stop-setting plunger spring (23) returns the plunger to the inactive position.

d. Adjustments. If stop-setting plunger spring (23, fig. 20) does not have sufficient tension to return plunger (16) and key lever (19) to inactive position, clip or stretch spring as necessary. If key lever in inactive position does not clear key lever stop (17) by one-thirty-second of an inch, loosen key lever stop screws, position stop, and tighten screws. If link lever spring (12) does not have sufficient tension to pull setting link slightly to the right as it moves toward stop, clip spring as necessary. With the carriage frame pointer (7, fig. 19) set at the first space on the front scale, the stop-setting link (10, fig. 20) must be positioned over the first tabulator stop on the left end of the tabulator rack. To adjust, loosen tabulator stop rack binding screws (15, fig. 21), turn tabulator stop rack adjusting screw after loosening nut (16), and position rack to align stop with setting link. Hold rack and tighten screws (15). Tighten rack adjusting screw and nut (16).

51. Tabulator Stop Rack Assembly

a. Components. The tabulator stop rack assembly is composed of the rack brackets, rack, rack adjusting screw, tabulator rack stops, and stop springs.

b. Description. The tabulator stop rack (1, fig. 20) is fastened to the rack brackets by a binding screw

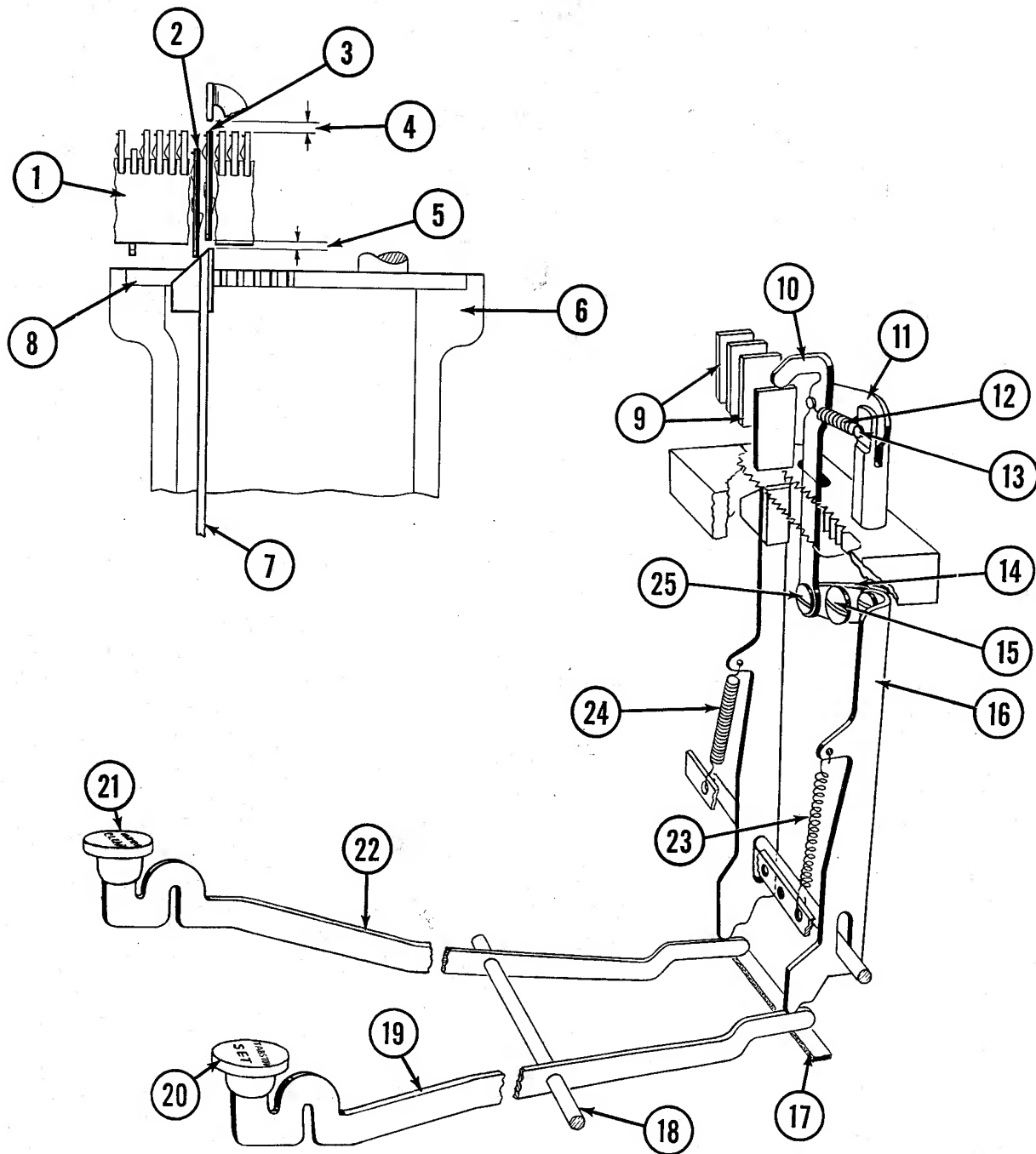

- | | |
|--|--|
| 1 Tabulator stop rack | 14 Rocker lever |
| 2 Tabulator stop in set position | 15 Tabulator stop-setting plunger screw |
| 3 Tabulator stop in unset position | 16 Stop-setting plunger |
| 4 Clearance of .040 to .042 inch | 17 Key lever stop |
| 5 Clearance of .002 to .003 inch | 18 Fulcrum rod |
| 6 Tabulator housing | 19 Set key lever |
| 7 Stop-clearing plunger | 20 Set key |
| 8 Housing plate | 21 Clear key |
| 9 Tabulator stops | 22 Clear key lever |
| 10 Stop-setting link | 23 Stop-setting plunger spring |
| 11 Link lever | 24 Stop-clearing plunger spring |
| 12 Link lever spring | 25 Stop-setting rocker lever pivot screw |
| 13 Stop-setting link lever fulcrum pin | |

Figure 20. Key set tabulator stop-setting and stop-clearing assemblies.

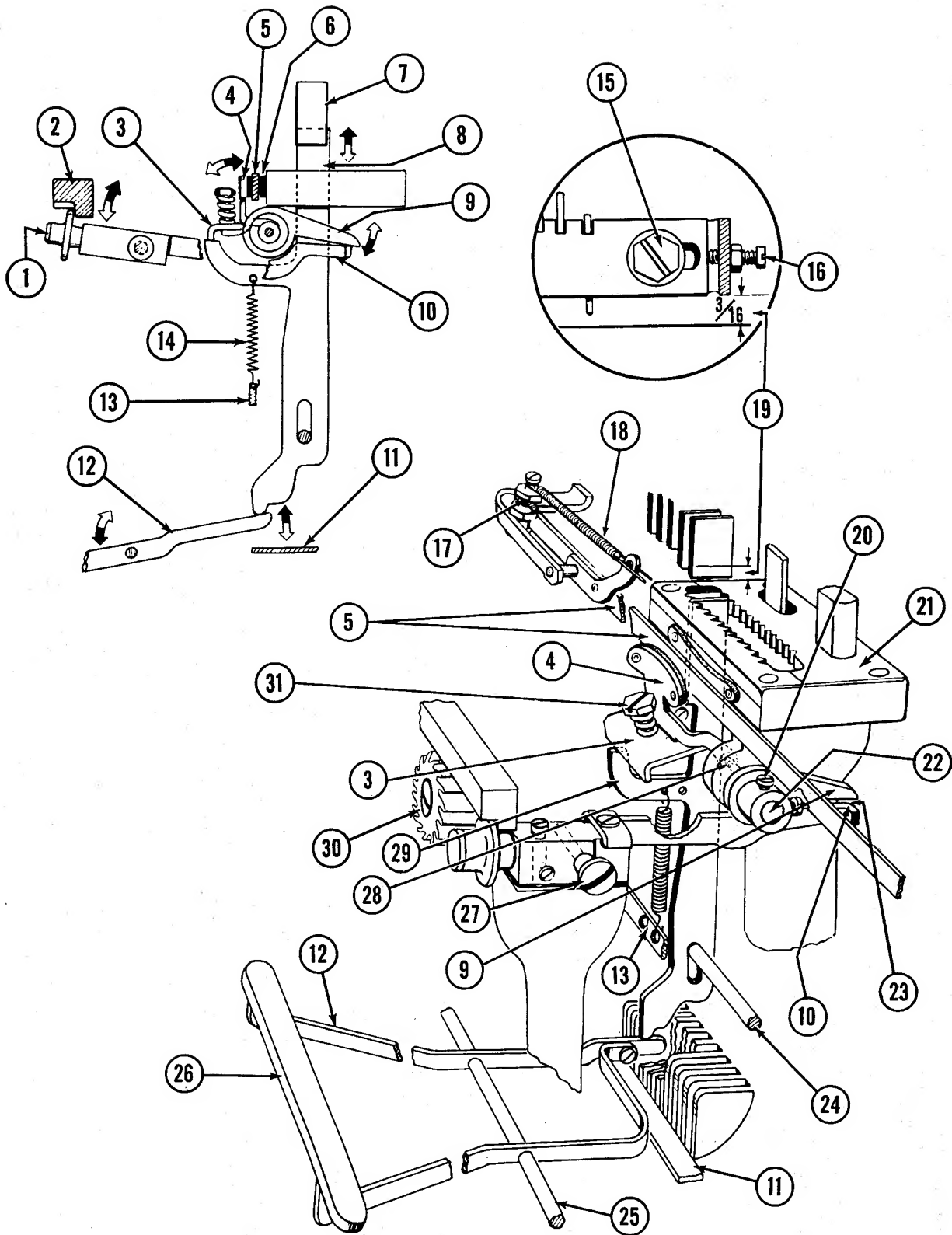

Figure 21. Tabulator assembly.

- 1 Tabulator lever roll
- 2 Carriage rack
- 3 Tabulator lever actuating plate
- 4 Brakeshoe
- 5 Brakeband
- 6 Stationary brakeshoe
- 7 Tabulator stop
- 8 Decimal stop
- 9 Shaft lever
- 10 Tabulator lever arm
- 11 Key lever stop
- 12 Tabulator key lever
- 13 Spring anchor plate
- 14 Decimal stop spring
- 15 Tabulator rack binding screw
- 16 Rack adjusting screw and nut

- 17 Brakeband anchor
- 18 Brakeband spring
- 19 Clearance of $\frac{3}{16}$ inch
- 20 Shaft lever setscrew
- 21 Rear tabulator housing top plate
- 22 Actuating shaft
- 23 Clearance of no less than .005 inch
- 24 Stop retainer screw
- 25 Fulcrum rod
- 26 Tabulator bar
- 27 Tabulator lever stud
- 28 Actuating plate shaft
- 29 Decimal stop arm
- 30 Pinion wheel
- 31 Brake arm tension spring adjusting screw

Figure 21. Tabulator assembly—Continued

(15, fig. 21) at each end. Each bracket is fastened to the main carriage frame by two binding screws. The rack has slots with a tabulator stop in each slot.

c. Operation. The tabulator rack supports the tabulator stops. The bottom edges of the stops are flush with the bottom edge of the tabulator rack when the stops are in the unset position. Each stop is held in position by a flat spring. When the setting link pushes the stop down, the spring holds the stop in the set position (2, fig. 20). In the set position, the stop protrudes below the rack so that it contacts the tabulator decimal stop (8, fig. 21) and stops the movement of the carriage.

d. Adjustment.

- (1) The tabulator stop rack adjusting screw (16, fig. 21) must be against the tabulator rack to prevent the rack from creeping. The rear side of the rack must clear the link lever and spring. Adjust by removing rack screws and placing washer or washers between rack and bracket. To make rack level its entire length, loosen rack screws, level rack, and tighten screws. If bottom of rack does not clear top of tabulator housing by three-sixteenths of an inch, form stop rack brackets. If stop-setting link in inactive position does not clear unset tabulator stops by .040 to .042 inch (4, fig. 20), form stop-setting plunger. Remove stop springs and form when necessary to adjust tension.
- (2) To check adjustments of rack, set each stop and tabulate to each. After tabulation, backspace and retabulate. If the carriage fails to retabulate to the same stop, the rack is not properly positioned.

52. Tabulator Assembly

a. Components. The tabulator assembly is composed of the tabulator key lever, tabulator decimal stop, tabulator lever actuating plate, brake arm, brakeshoe, actuating plate shaft, plate shaft lever and hub, tabulator lever arm, and tabulator lever.

b. Function. The tabulator assembly raises the carriage rack (2, fig. 21) out of mesh with the pinion wheel (30) and stops the carriage after it has moved the desired number of spaces. The tabulator assembly also applies a braking action to the carriage.

c. Operation. The tabulator key lever pivots on a fulcrum rod (25, fig. 21) fitted through the escape-ment frame. The key lever extends from the keyboard to the rear of the machine, with the rear end engaged in a slot in the tabulator housing. When depressed, the rear end of the key lever forces the tabulator decimal stop (8) up into the path of a set tabulator stop. The tabulator stop contacts the decimal stop and stops the movement of the carriage. When the decimal stop is forced up, the decimal stop arm (29) contacts the tabulator lever actuating plate (3) and forces the actuating plate and brakeshoe (4) to pivot rearward. The plate shaft (28) pivots rearward and forces the shaft lever (9) down against the tabulator lever arm (10). The tabulator lever arm, fastened to the tabulator lever, pivots the lever and forces the tabulator roll (1) against the rack. The roll lifts the rack out of engagement with the pinion and allows the carriage to move. When the actuating plate pivots the brakeshoe rearward, the shoe contacts the brakeband (5), which is attached to the tabulator rack bracket. The brakeband is centered between the actuating plate shoe and the stationary brakeshoe (6), which is attached to the tabulator housing. Pressure exerted by the brake-shoes on the brakeband retards the movement of the carriage.

d. Adjustments.

- (1) If tabulator key levers (12, fig. 21) are not free in the key lever comb slots, loosen setscrews on bottom side of tabulator bar (26) and position key levers properly. Form key levers or spread comb slots.
- (2) If tabulator decimal stop spring (14) does not have sufficient tension to return stop to its normal position, change position of spring in spring anchor plate (13) or in decimal stop.
- (3) If tabulator does not pivot freely with a minimum amount of play, loosen tabulator lever stud eccentric setscrew and position stud (27) in or out without turning stud. Hold stud and tighten setscrew.
- (4) If clearance is less than .005 inch (23) between actuating shaft lever and tabulator lever arm, loosen actuating shaft lever setscrews (20), position lever, and tighten setscrews. Check this clearance by depressing tabulator key and releasing it slowly to see that carriage rack meshes with pinion wheel before decimal stop releases set tabulator stop. The brakeband in its proper position must be parallel with the stationary brakeshoe and as close as possible to the shoe without dragging. To adjust, loosen brakeband anchor screw and position brakeband anchor (17). Hold anchor and tighten screws. To adjust brake tension, turn brake arm tension spring

screw (31). The tongue behind the screw locks the screw when the proper tension is obtained. Form tongue if necessary.

53. Key Set Tabulator Stop-Clearing Assembly

a. Components. The key set tabulator stop-clearing assembly is composed of the stop-clearing key lever and the stop-clearing plunger.

b. Function. The key set tabulator stop-clearing assembly enables the operator to clear all set stops by placing the carriage at the extreme left margin, depressing the clear key (21, fig. 20), and moving the carriage to the right margin while holding the clear key depressed.

c. Operation. The clear key lever (22, fig. 20) pivots on a fulcrum rod (18) fitted through the escapement frame. The key lever extends from the keyboard to the rear of the machine, with the rear end engaged in a slot in the tabulator housing. When depressed, the rear end of the key lever forces the stop-clearing plunger (7) up into the path of set tabulator stops (2). When the operator moves the carriage from left to right, the beveled blade of the plunger forces the set stops up into the unset position (3). When clearing only one stop, the plunger aligns with the set stop. When the clear key is depressed, the plunger moves up and forces the set stop into the unset position.

d. Adjustments. If stop-clearing plunger (7, fig. 20) does not fully restore set stops and clear the restored stops by .002 to .003 inch (5), form rear end of stop-clearing key lever.

Section XV. SUBCARRIAGE AND SHIFT ASSEMBLY

54. Subcarriage Mechanism

The subcarriage mechanism (fig. 22) is an inner frame that operates vertically within the main carriage. Proper fitting of the subcarriage is essential in securing good alignment and type impressions.

a. Components. The subcarriage consists of the subcarriage frame which supports the numerous paper feed parts.

b. Function. The subcarriage positions the typing paper in relation to the type for printing uppercase characters.

c. Operation. The subcarriage fits into the main carriage frame (24, fig. 22), with the subcarriage frame bearings (21) cradled in the lift frame hooks (19). The lateral paper guide shaft bracket exten-

sions (6) rest on the rear corners of the main carriage frame, and the heads of the on-feet adjusting screws (1) rest on the motion stop plates (2). The subcarriage roll (20, fig. 23) rests on the lift frame rail (22, fig. 22), and the carriage roll hanger latch (23) hooks beneath the rail. The subcarriage is held in the main carriage by the carriage controlling links (20). When the shift key lever (15, fig. 23) is depressed, the carriage frame rail, forced upward, pushes the roll and moves the subcarriage to the uppercase position until the heads of the motion adjusting screws (4, fig. 22) contact the motion stop plates (2).

55. Shift Mechanism

The shift mechanism (fig. 23) shifts the subcarriage upward and thus allows the uppercase characters to

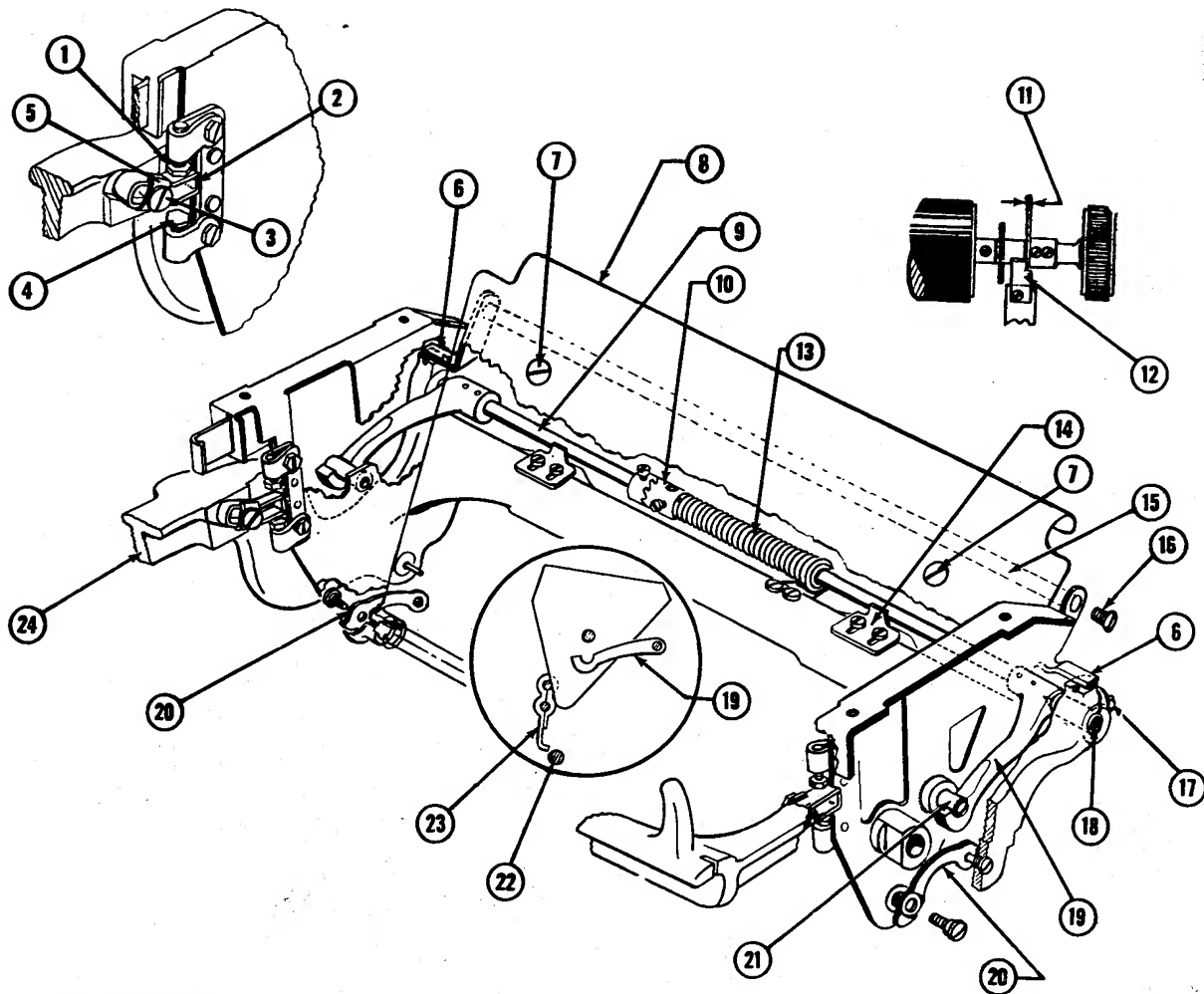

- | | |
|---|--|
| <ul style="list-style-type: none"> 1 On-feet adjusting screw 2 Motion stop plate 3 Motion stop plate screw 4 Motion adjusting screw 5 Motion stop plate strap 6 Lateral paper guide shaft bracket extension 7 Paper table screw 8 Paper table 9 Lift frame hook shaft 10 Lift frame hook spring clutch 11 Slight clearance between cylinder knob and carriage skeleton guide 12 Carriage skeleton guide | <ul style="list-style-type: none"> 13 Lift frame hook shaft spring 14 Lift frame hook shaft support 15 Lateral paper guide shaft 16 Lateral paper guide shaft screw 17 Lift frame hook adjusting stud lock screw 18 Lift frame hook adjusting stud 19 Lift frame hook 20 Carriage controlling link 21 Subcarriage frame bearings 22 Lift frame rail 23 Carriage roll hanger latch 24 Main carriage frame |
|---|--|

Figure 22. Subcarriage.

print. The shift mechanism consists of the key lever assembly, lift frame lock and shift lock assembly, and lift frame assembly.

a. Key Lever Assembly.

- (1) *Components.* The key lever assembly is composed of the left and right shift key levers and the shift key lever stop.
- (2) *Function.* The key lever assembly forces the lift frame into the uppercase position.

- (3) *Operation.* When the shift key lever (15, fig. 23) is depressed, the rear end of the key lever will contact and pivot the lift frame (6). The left shift key lever release stud (27) and right release stud (18) contact the release levers and cam the levers toward the front of the machine.

b. Lift Frame Lock and Shift Lock Assembly.

- (1) *Components.* The lift frame lock and shift

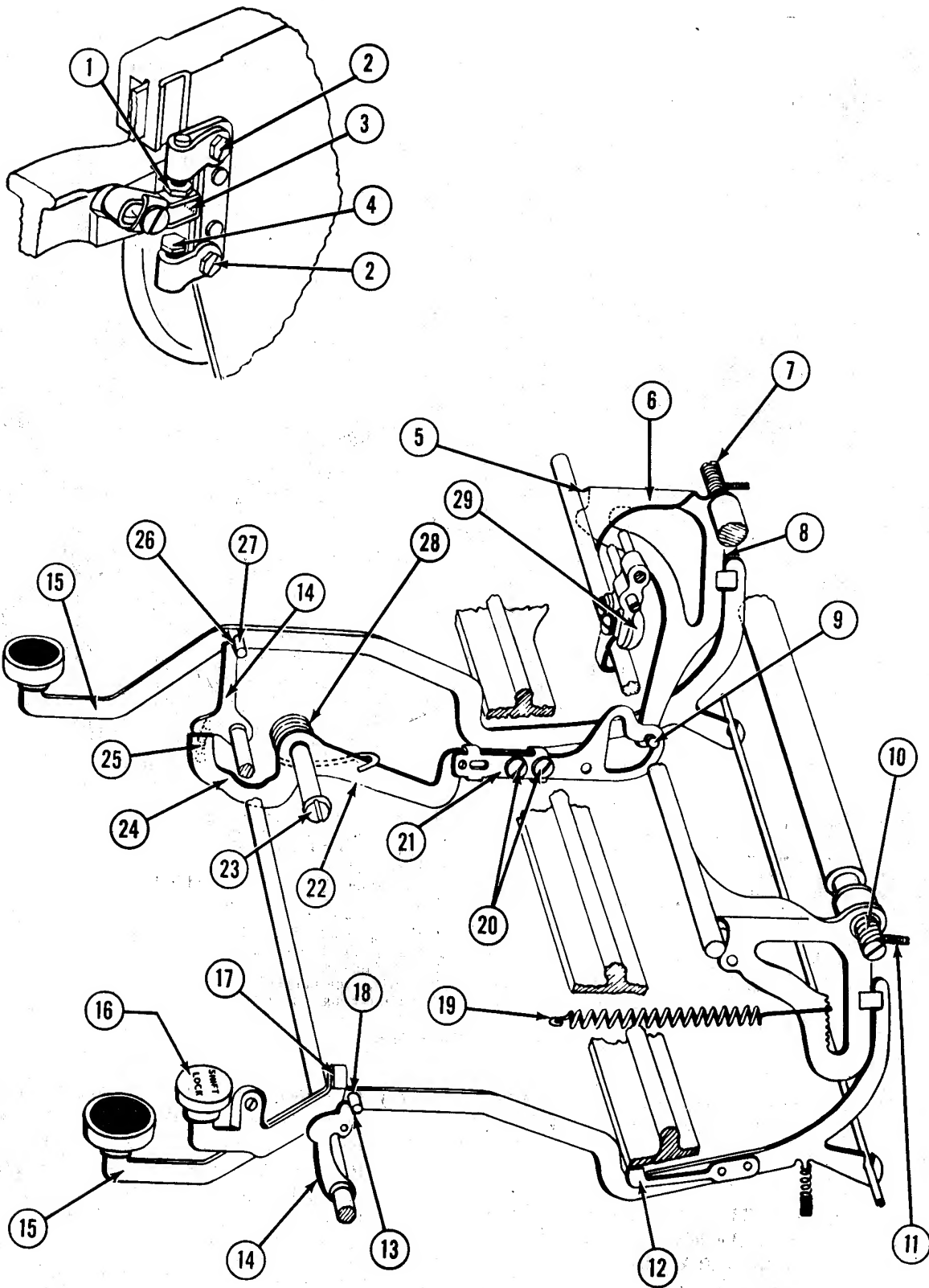

Figure 23. Shift mechanism.

- 1 On-feet adjusting screw
- 2 On-feet and motion adjusting screw lock screws
- 3 Motion stop plate
- 4 Motion adjusting screw
- 5 Lift frame forming point
- 6 Lift frame
- 7 Lift frame fulcrum screw
- 8 Clearance of .010 to .020 inch
- 9 Lift frame lock stud
- 10 Lift frame adjusting screw
- 11 Setscrew
- 12 Shift key lever stop
- 13 Clearance of .005 to .010 inch in lowercase position
- 14 Lock release lever
- 15 Shift key lever

- 16 Shift key lever lock
- 17 Shift lock loop extension
- 18 Right shift key lever release stud
- 19 Lift frame spring
- 20 Lift frame lock screws
- 21 Lift frame lock
- 22 Lift frame lock lever
- 23 Lift frame lock pivot stud
- 24 Lock lever forming point
- 25 Lock release lever shaft spring
- 26 Clearance of .005 to .010 inch in uppercase position
- 27 Left shift key lever release stud
- 28 Lift frame lock lever spring
- 29 Subcarriage roll

Figure 23. Shift mechanism.—Continued

lock assembly is composed of the left and right lock release levers, lock release lever fulcrum rod, lock lever, lock lever spring, lift frame lock, and lock stud.

- (2) *Function.* The lift frame lock and shift lock assembly lock the lift frame in the uppercase and lowercase positions.
- (3) *Operation.* When either the left or right key lever is depressed, the key lever stud (18 or 27, fig. 23) cams the lock release lever (14) toward the front of the machine. The extension on the left lock release lever contacts and pivots the lock lever. The lift frame lock lever (22) raises the lift frame lock (21) and frees the lift frame lock stud (9). When the lift frame lock frees the stud, it allows the lift frame to move to the uppercase position. After the lift frame has moved to the uppercase position, it is locked by depression of the shift key lever lock (16). When the shift key lever is depressed, the shift key lever lock, attached to the shift key lever, is moved downward with the key lever. The key lever stud cams the lock release lever toward the front of the machine, and the loop extension (17) on the rear of the shift key lever lock moves down behind the lock release lever stud. When the shift key lever lock is depressed, it pivots and the rear end moves from behind the release lever stud. Tension of the lock lever spring kicks the release lever forward and positions the cutout of the release lever over the key lever stud. The key lever stud seats in the cutout and locks the key lever in the uppercase position. The lock is released when the left shift key is depressed. The lock release lever moves out of the lock

position and the key lever is free to return to its normal position.

c. *Lift Frame Assembly.*

- (1) *Function.* The lift frame (6, fig. 23) when pivoted by the shift key lever forces the subcarriage into the uppercase position.
- (2) *Operation.* The lift frame pivots on the lift frame fulcrum screw (7) on the left side and on the lift frame adjusting screw (10) on the right side. The subcarriage roll (29), resting on the lift frame rail, is forced upward, and thus the subcarriage is forced into the uppercase position.

56. Adjustments to Subcarriage and Shift Assembly

a. *Subcarriage.*

- (1) *Lift frame hooks.* The lift frame hooks (19, fig. 22) must be positioned so that the lateral paper guide shaft bracket extensions (6) are resting upon the rear corners of the main carriage frame and the heads of the on-feet adjusting screws (1) are resting on the motion stop plates (2). To adjust, loosen lift frame hook eccentric stud lock screws (17), center lift frame hook shaft (9) by positioning studs (18), turn studs until subcarriage is properly seated, and tighten setscrews. To test this adjustment, remove subcarriage and depress either left or right lift hook so that opposite lift hook will be just clear of the main carriage frame. Form lateral paper guide shaft bracket extensions if they are not straight. The lift frame hook shaft supports (14) must be parallel with the shaft and must clear the shaft by not more than .003 inch. To adjust, loosen lift frame hook shaft support binding

screws, with strip of paper between lift frame hook shaft and lift frame hook shaft support. While holding lift frame hooks depressed, position supports and tighten screws.

- (2) *Lift frame hook spring.* The lift frame hook shaft spring (13) tension is adjusted for a light or heavy touch of the shift key. To adjust, loosen spring clutch setscrew, disengage spring clutch (10) from holding clutch, and turn spring clutch and spring toward front or rear of machine to increase or decrease tension. Replace spring clutch in engagement with holding clutch and tighten setscrew. Do not add tension to overcome a bind. Extra screw holes are provided in the clutches so that the setscrews may be positioned to avoid interference with the main carriage frame.
- (3) *Cylinder shaft knob.* The cylinder shaft knob must slightly clear carriage skeleton guide (11 and 12) without binding. To adjust, loosen cylinder shaft knob setscrews, position knob, and tighten setscrews. Test by turning cylinder knob and shifting carriage.

b. *Paralleling Cylinder and Ring and Cylinder Adjustment.*

- (1) The cylinder must be positioned so that it is parallel to the typeface to obtain an equally dark type impression across the typing paper. With the cylinder in this position and with one sheet of paper inserted, the type bar in forward motion contacts the segment abutment ring and the cylinder at the same time. Before adjusting, be sure cylinder is perfectly round. To adjust, loosen lift frame hook shaft supports (14, fig. 22) and motion stop plates (2) and remove the carriage controlling links (20). The movement of lift frame hooks by eccentric studs is shown in (4) figure 24. Parallel the cylinder by turning either the left or right lift hook shaft eccentric stud (1, fig. 24) as necessary. After paralleling the cylinder, turn each eccentric stud the same distance to adjust the ring and cylinder. Have high point of eccentric up to start.
- (2) With one sheet of paper in the machine, test ring and cylinder adjustment (fig. 25) by inserting a strip of paper between

cylinder (2) and typehead (1) and placing finger against type bar at abutment ring, holding type head (1) against paper and cylinder. Pull paper out, noting drag applied. Insert strip of paper between type bar (5) and abutment ring and place finger on type head to hold it against cylinder. Pull paper out, noting drag applied. Drag at both points should be equal. Make the test at each end and in the center of the carriage.

c. *Shift Adjustments.*

- (1) *Lift frame.* The lift frame (6, fig. 23) must be centered and must pivot freely with a minimum of sideplay. To adjust, loosen lift frame pivot screw setscrews (11), turn pivot screws, and tighten setscrews.
- (2) *Lift frame spring.* If lift frame spring (19) does not have sufficient tension to overcome weight of lift frame, lower spring in notches provided on lift frame. If spring has too much tension, raise spring in notches.
- (3) *Shift key levers.* If carriage in lowercase position does not have a .010- to .020-inch clearance (8) between shift key levers and lift frame, form shift key lever stops (12).
- (4) *Lock release lever.* If carriage in lowercase position does not have a .005- to .010-inch clearance (13) between lock release levers and shift key lever studs, form lift frame lock lever (22). If carriage locked in uppercase position does not have a .005- to .010-inch clearance (26) between left shift key lever stud and left lock release lever, form left lock release lever.
- (5) *Lift frame lock.* If lift frame lock has not sufficient pressure on lift frame lock studs to hold lift frame in uppercase and lowercase positions, loosen lift frame lock screws (20), position lock, and tighten setscrews.
- (6) *Carriage roll hanger latch.* If carriage in lowercase position does not have a .005- to .010-inch clearance between lift frame rail and carriage roll hanger latch, form latch. If latch does not clear lift frame rail with carriage in uppercase position, form latch.
- (7) *Motion stop plates.* If motion stop plates do not clear subcarriage frame by one-thirty-seconds of an inch, loosen motion stop plate screws, position plates, and tighten screws.

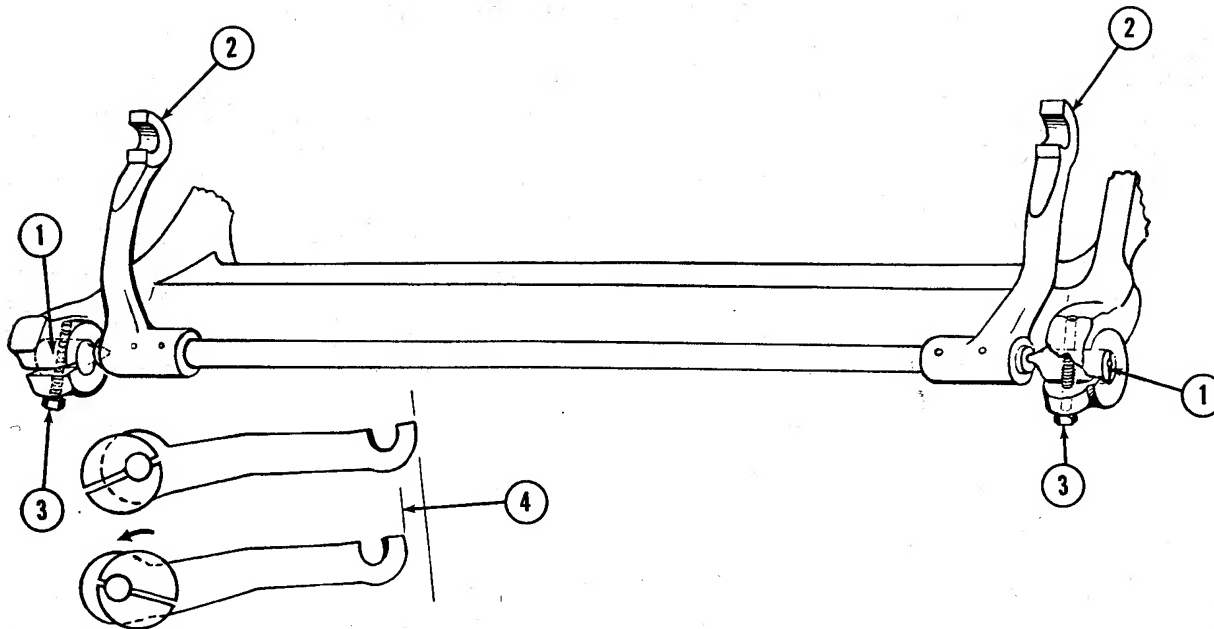

1 Eccentric stud
2 Lift frame hook

3 Eccentric stud lock screw
4 Movement of lift frame hooks by eccentric studs

Figure 24. Paralleling cylinder and ring and cylinder adjustment.

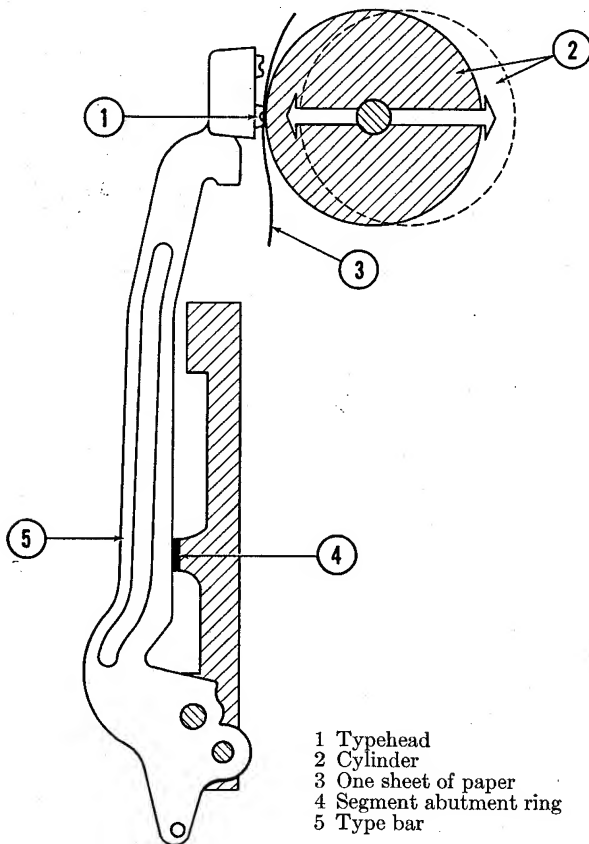

1 Typehead
2 Cylinder
3 One sheet of paper
4 Segment abutment ring
5 Type bar

Figure 25. Ring and cylinder, showing proper adjustment.

(8) *On-feet adjustment.* On-feet adjustment of the shift mechanism consists of adjusting the subcarriage so that the curved surface of the type head fits the curvature of the cylinder perfectly. The purpose of the adjustment is to produce a uniformly dark type impression. To adjust, loosen on-feet adjusting screw lock screws (2), turn adjusting screws as required, and tighten lock screws. Test with diagonal (/), $\frac{1}{2}$, or lowercase "h".

(9) *Motion adjustment.* Motion adjustment of the shift mechanism consists of adjusting the subcarriage to align upper case characters so that bottom of characters will print in true line with lowercase characters. To adjust, loosen motion adjusting screw lock screw (2), turn adjusting screws as required, and tighten lock screws. If after adjustment characters print in an uneven line with subcarriage locked in uppercase position, adjust lift frame lock. Test with lowercase "h", "r" or "x," using lowercase and uppercase characters alternately; for example hHhH. Test at both ends of cylinder.

Section XVI. CYLINDER SCALE FRAME ASSEMBLY

57. General

The cylinder scale frame assembly (fig. 26), attached to the lift frame, is moved from the lowercase position to the uppercase position by the lift frame.

58. Function

The cylinder scale is used to locate the writing line, and the card holders are used to hold cards or envelopes firmly against the cylinder.

59. Adjustments

a. *General.* Before making any adjustments to cylinder scale frame assembly, remove subcarriage by placing carriage in lowercase position and removing right carriage controlling link screw. Lock carriage in uppercase position and remove controlling link from stud. Remove left controlling link in same manner. Depress right lift hook with right hand and hold (3, fig. 27). Depress back of subcarriage with fingers of left hand (2) and pull front of carriage up with

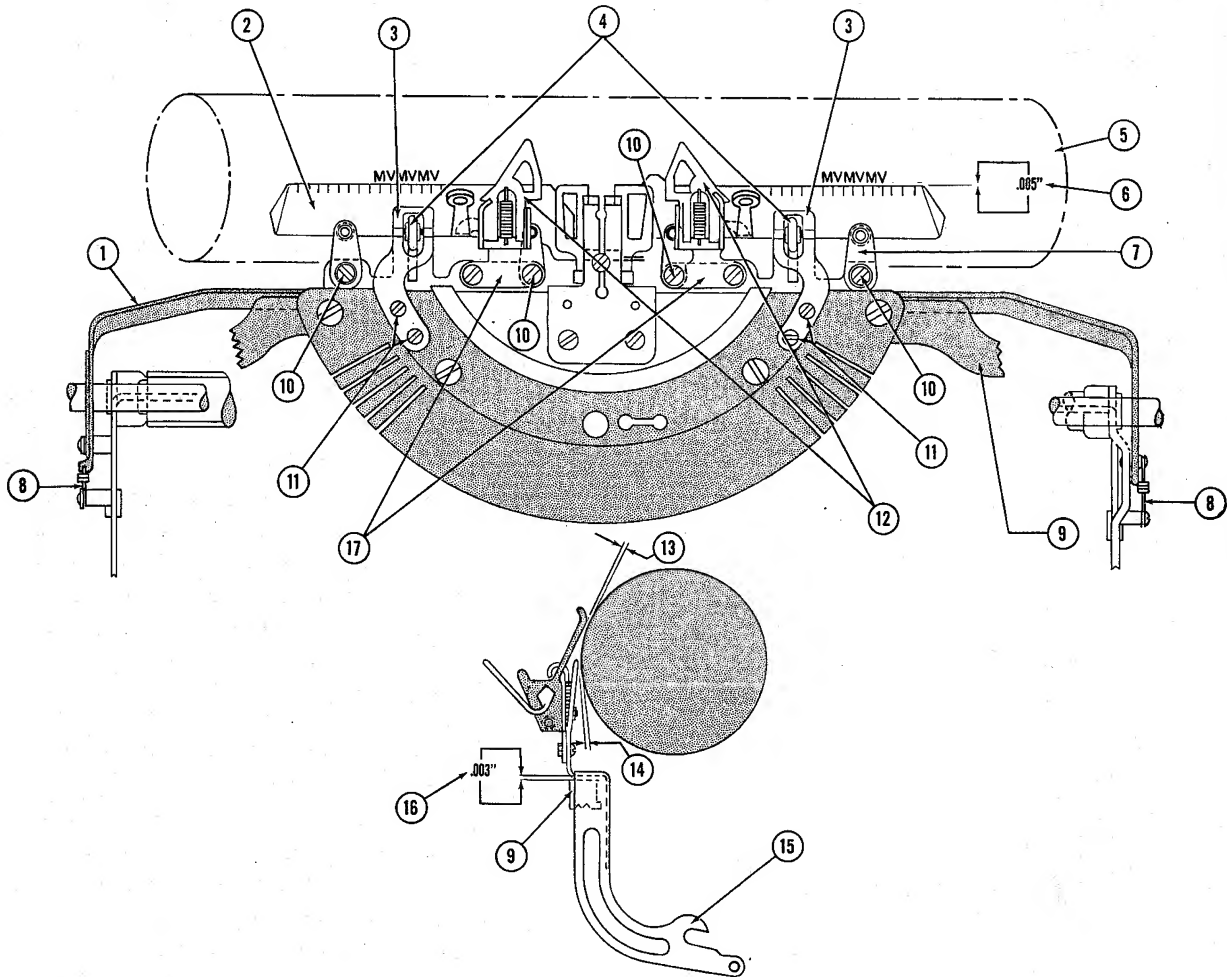

- 1 Cylinder scale frame
- 2 Cylinder scale
- 3 Scale frame guide
- 4 Scale frame bracket rolls
- 5 Cylinder
- 6 .005 inch below writing line
- 7 Scale support
- 8 Cylinder scale frame springs
- 9 Segment bracket

- 10 Cylinder scale screws
- 11 Guide roll brackets
- 12 Card holders
- 13 .050-inch clearance
- 14 1/2-inch clearance
- 15 Cylinder scale frame end
- 16 .003-inch clearance
- 17 Card holder brackets

Figure 26. Cylinder scale frame assembly.

thumb (1). Lift out subcarriage and release right hook slowly.

b. *Scale Frame Bracket Rolls.* The scale frame bracket rolls (4, fig. 26) must be centered in the scale frame guides (3) and clear top and bottom of guide slots. To adjust, loosen roll bracket (11) screws, position brackets, and tighten screws.

c. *Cylinder Scale Frame.* If the cylinder scale frame (1, fig. 26) does not clear segment bracket (9) by .003 inch (16) when lift frame is in lowercase position, form cylinder scale frame ends (15).

d. *Cylinder Scale.* The cylinder scale (2, fig. 26) must be parallel with the writing line, .005 inch below

the line (6), and graduations on scale must aline with center of printed character. To adjust, replace subcarriage, insert typing paper, and type several characters. Loosen cylinder scale screws and position scale supports (7) so that scale is beneath writing line and graduations are alined with characters. Aline scale with lowercase "i" or "v". Tighten cylinder scale screws.

e. *Card Holders.* If card holders (12, fig. 26) do not clear cylinder by .050 inch (13), form card holder brackets (17). If in the uppercase position card holders do not clear motion stop plates, loosen card holder screws, position holders, and tighten screws.

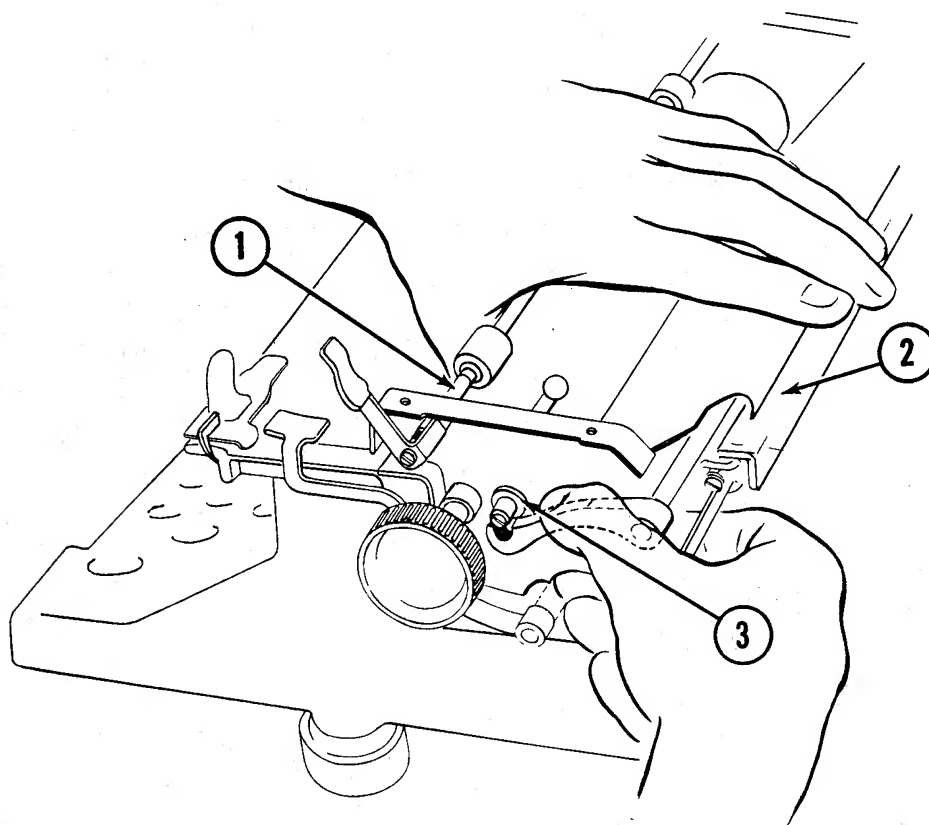

1 Pulling up front of carriage with thumb of left hand
2 Depressing back of subcarriage with fingers of left hand

3 Depressing right lift hook with right hand

Figure 27. Removal of subcarriage.

Section XVII. SEGMENT ASSEMBLY

60. General

The segment assembly (fig. 28) is fastened to the segment tie bar of the machine. It remains stationary and is slotted to hold type bars, which are held in place by a fulcrum wire (7, fig. 28).

61. Adjustments

The type guide (1, fig. 28), fastened to the segment

(10) by holding screws (11), must clear the cylinder by .125 inch and must be centered so that it will not retard to-and-fro movement of type bars (6). The type bars must enter the slot in the type guide with a minimum of sideplay without binding. Adjust type guide opening after loosening adjusting screw lock screw (2) and turning adjusting screw (3) in to open type guide and out to close guide.

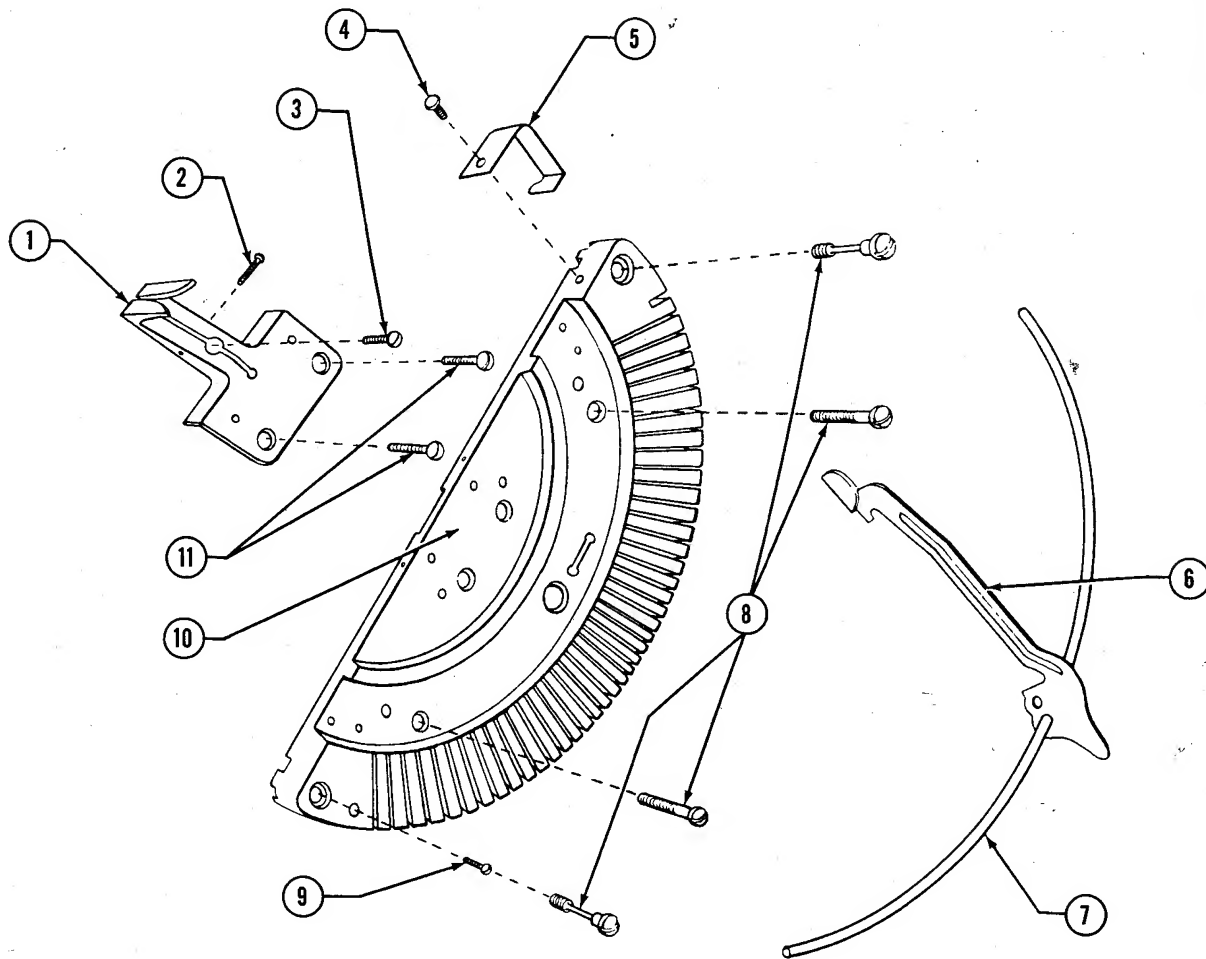

- 1 Type guide
- 2 Type guide adjusting screw lock screw
- 3 Type guide adjusting screw
- 4 Retainer plate holding screw
- 5 Fulcrum wire retainer plate
- 6 Type bar

- 7 Fulcrum wire
- 8 Segment holding screws
- 9 Wire retaining screw
- 10 Segment
- 11 Type guide holding screws

Figure 28. Segment assembly.

62. General

Alinement of type pertains to the relation of the characters to one another as they appear in the type-written work. Proper alinement of characters consists of even horizontal spacing, proper positioning on the writing line, and uniformly even printing. Before attempting to aline the type, make sure that shift (par. 56c), escapement (pars. 25-29), and ribbon cover (pars. 44 and 45) adjustments are correct. The type bars must move freely in the segment and enter the type guide without hindrance. Never try to aline type if it is off more than .005 inch. Resolder type head to bar.

63. Alinement Check

The uppercase "N" is used as a guide for alining the uppercase characters, and the lowercase "n" is used as a guide for the lowercase characters. Type all characters several times. If a majority of characters vary from the "N" in the same direction, center the character "N" first to avoid the necessity of adjusting all the type. The character "H" may be used as the master character.

64. Alinement Methods

a. Lowering Character. To lower character (fig. 29) if it prints higher than the master character, use one of the following methods:

- (1) Place mauling pliers (1) on back side of type bar (2) and crimp type bar. Crimping

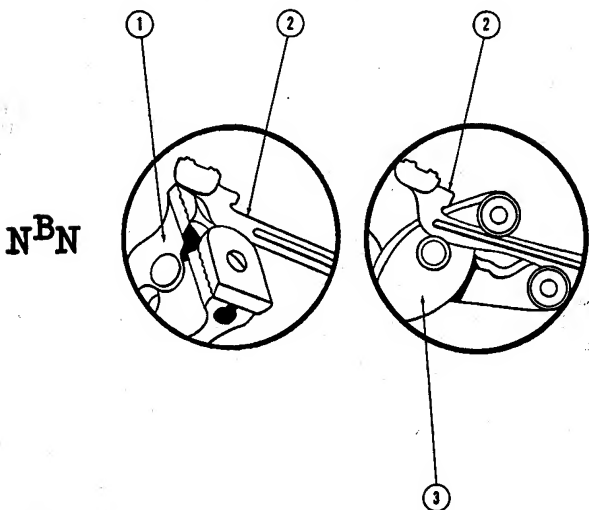

- 1 Mauling pliers
- 2 Type bars
- 3 Type bar rollers

Figure 29. Lowering character.

back side of type bar throws type head forward and lowers printed character in relation with the master "N".

- (2) Use type bar rollers (3), bending type bar toward cylinder.

b. Raising Character. To raise character (fig. 30) if it prints lower than the master character, use one of the following methods:

- (1) Place mauling pliers (2) on front side of type bar (1) and crimp type bar. Crimping front side of type bar throws type head backward and raises printed character in relation with the master "N."
- (2) Use type bar rollers (3), bending type bar away from cylinder.

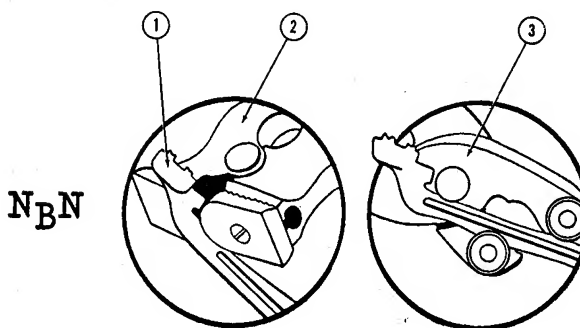

- 1 Type bar
- 2 Mauling pliers
- 3 Type bar rollers

Figure 30. Raising character.

c. Moving Character Laterally. Move character to left or right to insure proper horizontal spacing if character prints too close to preceding master character or too far from master character. Use one of the following methods for lateral movement of character (fig. 31).

- (1) If printed character shows a full typed impression but is out of position, use type bar offsetting pliers (1) to adjust position. Caution must be taken when using the offsetting pliers.
- (2) If character is not printing fully, the position is due to a twisted type head. Use type bar twisters (3) to adjust position.
- (3) Bend type bar (2) slightly.

d. Straightening Character. To straighten character if it is twisted (fig. 32), use type bar twisters (1), one holding and one twisting.

NBN

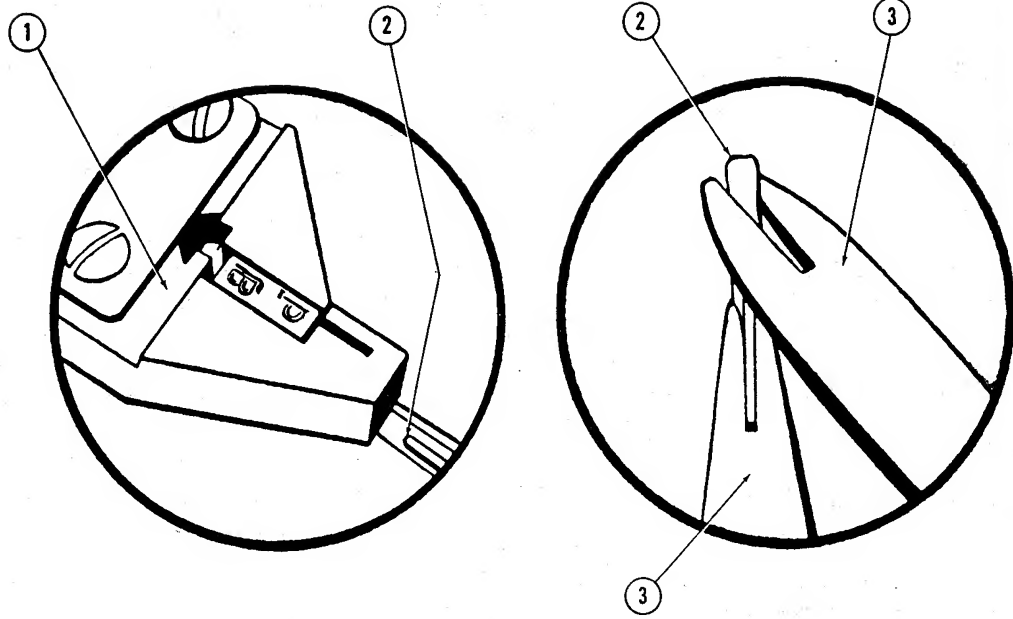

1 Type bar offsetting pliers
2 Type bar

3 Type bar twisters

Figure 31. Moving character laterally.

NBN

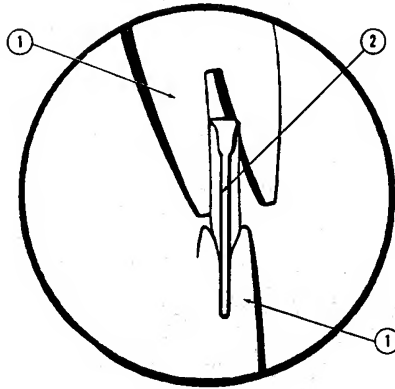

1 Type bar twisters

2 Type bar

Figure 32. Straightening character.

Section XIX. DISASSEMBLY AND REASSEMBLY

65. Main Carriage

For main carriage mechanism, see paragraphs 13 and 14.

a. Removal.

- (1) Move main carriage (fig. 2) to extreme right.
- (2) Disconnect drawband from drawband stud (11, fig. 2) and hold drawband.
- (3) Move main carriage to extreme left.
- (4) Hook drawband to anchor stud located on right side of top of typewriter frame.
- (5) Remove four tabulator housing screws located on lower end of tabulator housing (6, fig. 20).
- (6) Remove tabulator housing by pushing housing up and pulling down and out toward rear of machine.
- (7) Remove two front scale plate screws (3, fig. 1).
- (8) Remove carriage frame stop (13, fig. 2) from under right side of front scale plate (2, fig. 1).
- (9) Slide front scale plate off machine.
- (10) Lift front of main carriage up about 1 inch and slide carriage off wayrod (12, fig. 2).

b. Disassembly.

- (1) Loosen right carriage frame roll eccentric stud binding screw (5, fig. 2) and remove eccentric.
- (2) Remove left carriage frame roll (3, fig. 2).
- (3) Remove the two carriage frame pointer screws and carriage frame pointer (7, fig. 19).
- (4) Remove marginal stop release lever shoulder screw and the release lever (8, fig. 19).
- (5) Remove marginal stop release lever spring screw and remove spring (9, fig. 19).
- (6) Remove the two bell trip adjuster screws and bell trip adjuster (6, fig. 19).
- (7) Remove the two binding screws holding the cover plate (9, fig. 1) over the line space lever, and remove cover plate.
- (8) Remove the two line space rubber stops (11, fig. 5) from eccentric adjusting studs.
- (9) Remove the two setscrews (14, fig. 5) from line space eccentric adjusting studs.

- (10) Remove the two line space eccentric adjusting studs (15, fig. 5).
- (11) Remove line space lever pivot screw (10, fig. 5).
- (12) Remove line space lever (12, fig. 5).
- (13) Remove line space lever eccentric pivot stud nut (17, fig. 5).
- (14) Remove line space lever eccentric pivot stud (13, fig. 5).
- (15) Remove carriage rack frame release lever spring (6, fig. 2).
- (16) Remove carriage rack frame end fulcrum screw (7, fig. 2).
- (17) Remove carriage rack (8, fig. 12).
- (18) Remove carriage skeleton guide screw.
- (19) Remove carriage skeleton guide (12, fig. 22).
- (20) Remove the two motion stop plate screws (3, fig. 22).
- (21) Remove motion stop plate straps, left and right (5, fig. 22).
- (22) Remove motion stop plates, left and right (2, fig. 22).
- (23) Remove lift hook shaft support screws.
- (24) Remove carriage frame bearings, assembled, and lift hook shaft support (14, fig. 22).
- (25) Remove the two wayrod bracket screws (8, fig. 1).
- (26) Remove wayrod (12, fig. 2).
- (27) Remove the two tabulator stop rack binding screws (15, fig. 21).
- (28) Remove tabulator stop rack (1, fig. 20).
- (29) Remove tabulator brakeband spring support and anchor screws.
- (30) Remove tabulator brakeband anchors (17, fig. 21) and nuts.
- (31) Remove tabulator brakeband (5, fig. 21).

c. Reassembly.

- (1) Replace tabulator stop rack on brackets, with elongated holes in rack toward front of machine.
- (2) Replace rack binding screws and washers if necessary.
- (3) Replace brakeband anchors and nuts.
- (4) Replace brakeband.

- (5) Replace brakeband spring anchor screw, right anchor screw, and spring support.
- (6) Replace carriage frame bearings, assembled. Be sure that bearing sleeves are toward the inside and the bearing with drawband stud is on the right.
- (7) Replace lift hook shaft supports.
- (8) Replace motion stop plates, flat side up.
- (9) Replace motion stop plate straps and screws.
- (10) Replace carriage skeleton guide and screws.
- (11) Replace carriage rack. Fit rack on left carriage rack frame end screw.
- (12) Replace carriage rack frame end fulcrum screw.
- (13) Connect carriage rack spring.
- (14) Replace line space lever eccentric pivot stud.
- (15) Replace pivot stud nut.
- (16) Replace line space lever on stud.
- (17) Replace line space lever pivot screw.
- (18) Replace the two line space eccentric adjusting studs.
- (19) Replace the two line space eccentric adjusting stud setscrews.
- (20) Replace the two line space rubber stops.
- (21) Replace line space lever cover plate and screws.
- (22) Replace bell trip adjuster and screws.
- (23) Replace marginal stop release lever spring and screw.
- (24) Replace marginal stop release lever and shoulder screw.
- (25) Replace carriage frame pointer and screws.
- (26) Replace left carriage frame roll and screw.
- (27) Replace carriage frame roll eccentric.
- (28) Tighten carriage frame roll eccentric set-screw.

66. Mainspring

For mainspring mechanism, see paragraphs 15 and 16.

a. Removal.

- (1) Hold spring drum (3, fig. 3) and disconnect drawband (1, fig. 4) from anchor stud located on drum.

- (2) Allow drum to turn slowly to release all tension.
- (3) Remove spring drum hanger screws.
- (4) Remove mainspring, assembled (fig. 4).

b. Disassembly.

- (1) Pry off spring drum cover plate (1, fig. 3).
- (2) Disconnect spring from anchor collar stud (16, fig. 3) and drum stud.
- (3) Remove spring (18, fig. 3).
- (4) Remove tension adjusting knob spring screw (6, fig. 3).
- (5) Remove tension adjusting knob spring (12, fig. 3).
- (6) Remove tension adjusting knob (9, fig. 3).
- (7) Remove spring drum shaft screw (5, fig. 4) and hanger (7, fig. 3).
- (8) Remove spring drum shaft anchor collar screw (2, fig. 3) and anchor collar (17).
- (9) Remove spring drum shaft (14, fig. 3), cones (15), ball bearings (4), and spacer (5) from drum.

c. Reassembly.

- (1) Replace cone on drum shaft with flat side down.
- (2) Replace drum on shaft.
- (3) Replace cone spacer on shaft.
- (4) Replace ball bearings.
- (5) Replace outside cone on shaft with beveled edge toward inside.
- (6) Replace spring drum shaft anchor collar and screw on shaft.
- (7) Replace spring drum hanger on shaft.
- (8) Replace spring drum shaft screw.
- (9) Replace tension adjusting knob and spring in hanger.
- (10) Replace tension adjusting knob spring screw.
- (11) Replace mainspring. Hook outside end to drum stud and inside end to collar stud.
- (12) Snap spring drum cover plate on drum.

67. Motion and Shift, Cylinder Scale, and Paper Feed

a. Removal of Lift Frame, Lock Release Shaft, and Cylinder Scale.

- (1) Remove lift frame spring (19, fig. 23).
- (2) Remove ribbon guide actuating lever bracket (3, fig. 18) screws.

- (3) Loosen lift frame pivot screw lock screws (20, fig. 23).
 - (4) Remove lift frame pivot screws.
 - (5) Remove tabulator lever arm (10, fig. 21) and screw.
 - (6) Lift out lift frame (6, fig. 23) assembled with cylinder scale.
 - (7) Remove cylinder scale frame spring (8, fig. 26).
 - (8) Remove cylinder scale (2, fig. 26) from lift frame.
 - (9) Remove lock release lever shaft spring (25, fig. 23).
 - (10) Remove lock release lever shaft pivot screws, which pass through the type-writer frame and screw into each end of the lever shaft.
 - (11) Remove shaft by working out slowly.
 - (12) Disconnect lift frame lock lever spring (28, fig. 23).
 - (13) Loosen lift frame lock pivot stud setscrew.
 - (14) Remove pivot stud (23, fig. 23).
 - (15) Remove lift frame lock assembled with lift frame lock lever spring (28, fig. 23).
- b. *Disassembly of Cylinder Scale.*
- (1) Remove card holder screws and card holders (12, fig. 26).
 - (2) Remove cylinder scale screws (10, fig. 26), cylinder scale spacers located under screws, and cylinder scale (2, fig. 26).
- c. *Reassembly of Cylinder Scale.*
- (1) Replace cylinder scale, cylinder scale spacers, and screws.
 - (2) Replace card holders and screws.
 - (3) Install cylinder frame ends on lift frame studs.
 - (4) Replace cylinder scale frame springs.
- d. *Disassembly of Paper Feed Mechanism.*
- (1) Loosen right cylinder shaft knob screws (4, fig. 7).
 - (2) Remove cylinder shaft knob.
 - (3) Disconnect detent arm spring (8, fig. 7).
 - (4) Remove line space disengaging cam (6 fig. 7).
 - (5) Loosen cylinder shaft screws (5, fig. 7).
 - (6) Pull cylinder shaft out to left.
 - (7) Remove cylinder.
 - (8) Remove cylinder shield.
 - (9) Lift out front feed roll shaft (3, fig. 8).
 - (10) Depress rear feed roll hangers (15, fig. 8) and remove rear feed roll shaft (13).
 - (11) Remove front and rear feed roll shaft screws.
 - (12) Remove feed rolls (3 and 13, fig. 8) and collars.
 - (13) Loosen variable knob setscrew lock screw (14, fig. 6).
 - (14) Remove variable knob setscrew (13, fig. 6).
 - (15) Remove variable knob (17, fig. 6).
 - (16) Remove line space drum cover plate screws (3, fig. 6).
 - (17) Remove drum cover plate (4, fig. 6).
 - (18) Remove expander levers (10, fig. 6).
 - (19) Remove friction bands (9, fig. 6).
 - (20) Slide line space drum (8, fig. 6) and ratchet (7) off cylinder shaft.
 - (21) Remove line space plunger spring (3, fig. 5).
 - (22) Remove line space pawl screw (8, fig. 5) and line space pawl (19).
 - (23) Remove line space pawl spring screw (5, fig. 5) and spring (7).
 - (24) Pull out line space plunger (18, fig. 5).
 - (25) Remove detent arm screw (23, fig. 5), detent arm (21), detent spring (4), detent bushing under spring, and line space adjuster flat tension spring (24).
 - (26) Remove line space adjuster screw, which passed through the adjusting lever and screws into the adjuster.
 - (27) Remove line space adjuster (25, fig. 5).
 - (28) Remove line space adjusting lever guide screw.
 - (29) Remove line space adjusting lever (1, fig. 5).
 - (30) Remove lateral paper guide shaft screw (16, fig. 22).
 - (31) Remove lateral paper guide (1, fig. 1), shaft (15, fig. 22), and spring, which is attached to guide.
 - (32) Pull lateral paper guide off shaft.
 - (33) Remove the two paper table screws (7, fig. 22).
 - (34) Loosen lower paper table screws.
 - (35) Pull paper table (8, fig. 22) out.

- (36) Remove paper holder bail release lever screw.
- (37) Remove paper holder bail release lever, assembled (3, fig. 7).

e. Reassembly of Paper Feed Mechanism.

- (1) Replace paper holder bail release lever, assembled.
- (2) Replace paper holder bail release lever screw.
- (3) Replace paper table.
- (4) Replace upper paper table screws and tighten.
- (5) Assemble lateral paper guide and spring to shaft.
- (6) Replace lateral paper guide, shaft, and spring.
- (7) Replace lateral paper guide shaft screw.
- (8) Assemble front and rear feed rolls and collars to shafts.
- (9) Replace feed roll shaft screws.
- (10) Install line space adjusting lever.
- (11) Attach line space adjuster to line space adjusting lever.
- (12) Replace line space adjusting lever guide screw.
- (13) Replace line space adjusting lever flat tension spring, detent bushing, detent spring, detent arm, and detent arm screw and attach to subcarriage frame.
- (14) Insert line space plunger.
- (15) Replace line space pawl spring and screw on plunger.
- (16) Replace line space pawl and screw on plunger.
- (17) Attach line space plunger spring to plunger and subcarriage frame.
- (18) Depress rear feed roll hangers and install rear feed rolls, assembled.
- (19) Install front feed rolls, assembled.
- (20) Install cylinder shield.
- (21) Replace cylinder.
- (22) Replace line space drum and ratchet on cylinder shaft.
- (23) Replace friction bands.
- (24) Replace expander levers.
- (25) Replace friction band pins.
- (26) Replace expander lever pin.

- (27) Replace line space drum cover plate and screws.
- (28) Replace variable line space knob, assembled on cylinder on shaft.
- (29) Position knob so that line space cone lock rod lever locks the line space cone lock rod.
- (30) Hold knob and replace knob setscrew.
- (31) Tighten setscrew lock screw.
- (32) Insert cylinder shaft through subcarriage frame and cylinder.
- (33) Tighten cylinder shaft screws.
- (34) Replace right cylinder shaft knob and tighten setscrews.
- (35) Replace paper bail studs, short stud on left.
- (36) Replace paper bail on studs.
- (37) Connect springs to studs, short spring on left side.
- (38) Replace disengaging cam between drum and ratchet and on detent roll.
- (39) Connect detent roll arm spring under stud.

68. Escapement and Backspace Mechanism

a. Removal of Escapement Mechanism.

- (1) Remove ribbon shift slide link screws and link (12, fig. 18).
- (2) Disconnect ribbon guide (4, fig. 18) from ribbon guide actuating lever (5).
- (3) Remove upper backspace link screw and nut (4, fig. 14).
- (4) Unhook backspace link spring (7, fig. 14).
- (5) Remove lower backspace link screw (9, fig. 14).
- (6) Remove backspace link (5, fig. 14).
- (7) Loosen ribbon feed actuating shaft lever screw (20, fig. 17).
- (8) Remove the two escapement frame binding screws (18, fig. 11).
- (9) Remove escapement frame (12, fig. 12).
- (10) Remove key set tabulator fulcrum and spacer, which are located in front of lower part of escapement frame.
- (11) Remove escapement frame base screws, which extend through escapement frame base into the typewriter frame.
- (12) Remove escapement frame base.

b. Disassembly of Escapement and Backspace Mechanism.

- (1) Remove ribbon guide actuating lever (5, fig. 18) and bracket (3).
 - (2) Remove ribbon shift slide bracket screws and bracket with slide (10).
 - (3) Loosen backspace carrier eccentric bushing setscrew (23, fig. 14).
 - (4) Remove carrier eccentric bushing (24, fig. 14) and washers, if any.
 - (5) Loosen tabulator lever stud eccentric setscrew (19, fig. 14).
 - (6) Remove stud eccentric (20, fig. 14) and tabulator lever.
 - (7) Remove backspace pawl carrier (2, fig. 14) and pawl, assembled.
 - (8) Remove backspace pawl pivot shoulder screw (21, fig. 14).
 - (9) Remove backspace pawl (17, fig. 14).
 - (10) Remove backspace pawl carrier spring screw spacer and spring (3, fig. 14).
 - (11) Remove universal bar frame stop screws and stop (13, fig. 10).
 - (12) Remove universal bar spring (10, fig. 10).
 - (13) Loosen universal bar spring support setscrew.
 - (14) Remove spring support (11, fig. 10).
 - (15) Remove frame shaft nut (4, fig. 10).
 - (16) Remove frame shaft (5, fig. 10).
 - (17) Remove universal bar.
 - (18) Loosen rocker arm fulcrum pin setscrew (17, fig. 11).
 - (19) Remove rocker arm fulcrum (16, fig. 11).
 - (20) Remove rocker arm, assembled (7, fig. 10).
 - (21) Remove ribbon guide actuating lever stop screws.
 - (22) Remove lower ribbon guide actuating lever stop (20, fig. 18).
 - (23) Remove loose dog spring (9, fig. 11).
 - (24) Loosen loose dog spring support setscrew and remove support (10, fig. 11).
 - (25) Loosen escapement rocker arm fulcrum pivot screw setscrew (24, fig. 11).
 - (26) Remove escapement rocker, assembled.
 - (27) Loosen loose dog pivot stud setscrew (20, fig. 11).
 - (28) Remove loose dog (13, fig. 11) and stud (19).
 - (29) Remove loose dog stop screw and stop (12, fig. 11).
 - (30) Remove backlash pawl screw, spring (23, fig. 11), and backlash pawl (5).
 - (31) Remove pinion wheel screw.
 - (32) Remove pinion wheel (3, fig. 12).
 - (33) Loosen wheel shaft adjusting nut lock screw (11, fig. 12).
 - (34) Remove wheel shaft adjusting nut (10, fig. 12).
 - (35) Remove wheel shaft cone (9, fig. 12).
 - (36) Remove escapement wheel (4, fig. 12) and ball bearings.
- c. Reassembly of Escapement and Backspace Mechanism.*
- (1) Replace 7 escapement wheel ball bearings in front of escapement frame.
 - (2) Replace escapement wheel.
 - (3) Hold wheel and replace 8 escapement wheel ball bearings in the back of escapement frame.
 - (4) Replace cone.
 - (5) Replace wheel shaft adjusting nut and tighten lock screw.
 - (6) Replace pinion wheel on wheel shaft, with flat side toward escapement wheel and teeth pointing toward right side of machine.
 - (7) Replace pinion wheel screw.
 - (8) Replace backlash pawl spring and pawl on screw.
 - (9) Replace backlash pawl spring, pawl, and screw on escapement rocker. Fit end of spring into slot on bottom of rocker.
 - (10) Replace loose dog stop and screw on rocker.
 - (11) Replace loose dog and pivot stud on rocker.
 - (12) Replace escapement rocker and fulcrum pin in escapement frame.
 - (13) Tighten pin setscrew.
 - (14) Replace loose dog spring support and tighten setscrew.
 - (15) Connect loose dog spring to loose dog support.
 - (16) Replace rocker arms, assembled, and pin. Tighten setscrew.
 - (17) Aline universal bar with holes in rocker arm.
 - (18) Insert universal bar frame shaft through rocker arms and universal bar frame arms.

- (19) Replace nut on universal bar frame shaft.
- (20) Replace universal bar frame spring support and tighten screws.
- (21) Connect universal bar spring to universal bar stud and support.
- (22) Replace universal bar frame stop screws.
- (23) Replace backspace pawl carrier spring, spacer, and screw on carrier.
- (24) Replace backspace pawl and shoulder screw on carrier.
- (25) Replace carrier and pawl, assembled, on escapement rocker fulcrum pivot screw.
- (26) Insert backspace pawl carrier eccentric bushing through carrier.
- (27) Tighten carrier eccentric setscrew.
- (28) Replace tabulator, assembled, on escapement frame. Fit short end of wheel lock in notch of carrier.
- (29) Replace tabulator lever eccentric stud and tighten setscrew.
- (30) Replace ribbon shift slide and bracket screws on universal bar.
- (31) Replace ribbon guide actuating lever stop and screws.
- (32) Replace ribbon guide actuating lever and bracket in ribbon shift slide.
- (10) Remove ribbon shift lever detent pin spring (14, fig. 18), and detent pin (16).
- (11) Remove ribbon shift lever pivot screw (18, fig. 18), bushing, and lift frame spring bracket which is held by screw.
- (12) Remove ribbon shift lever (17, fig. 18).
- (13) Remove right ribbon bracket screws.
- (14) Remove right ribbon bracket, assembled.
- (15) Remove ribbon feed actuating shaft retaining plate screws and plates (19, fig. 17).
- (16) Remove ribbon feed actuating shaft (22, fig. 17), assembled.
- (17) Remove ribbon guide guard screws.
- (18) Remove ribbon guide guard.
- (19) Remove ribbon guide (4, fig. 18).

b. Disassembly.

- (1) Loosen ribbon feed pawl lever binding screw (30, fig. 17).
- (2) Remove ribbon feed pawl (18, fig. 17) and holding pawl (24) from shaft.
- (3) Loosen ribbon feed pawl pin setscrew (33, fig. 17).
- (4) Remove ribbon feed pawl pin which extends through end of feed pawl and feed pawl lever (32, fig. 17).
- (5) Remove ribbon feed pawl (18, fig. 17).
- (6) Slide ribbon feed actuating shaft lever (21, fig. 17) off shaft.
- (7) Loosen ribbon feed actuating shaft collar setscrew and remove collar.
- (8) Remove ribbon shifting arm disk nut (49, fig. 17), spring (48), and disk (47).
- (9) Remove ribbon detent lever tension spring (45, fig. 17).
- (10) Remove ribbon detent lever adjusting screw (41, fig. 17).
- (11) Remove ribbon detent lever pivot screw.
- (12) Remove ribbon detent lever (42, fig. 17).
- (13) Loosen left spool shaft gear (40, fig. 17) setscrew.
- (14) Loosen left spool shaft collar setscrew (35, fig. 17).
- (15) Loosen left spool shaft bushing setscrew (37, fig. 17).
- (16) Remove left spool shaft, collar, bushing, gear, and spool shaft spring (39, fig. 17), and the shifting arm will drop out.

69. Ribbon Mechanism

a. Removal.

- (1) Remove ribbon spools and ribbon.
- (2) Remove ribbon feed drive shaft extension (25, fig. 17).
- (3) Hold feed drive shaft and remove ribbon feed ratchet wheel (27, fig. 17) with shifting arm disk (17).
- (4) Loosen feed drive shaft gear setscrews (16, fig. 17).
- (5) Loosen ribbon detent collar (43, fig. 17) setscrew.
- (6) Remove ribbon shifting arm disk (47, fig. 17) and feed drive shaft (15) by pulling shaft out to left of machine.
- (7) Remove ribbon feed drive shaft gears (14, fig. 17) and detent collar (43) from machine.
- (8) Remove left ribbon spool bracket (52, fig. 17) screws.
- (9) Remove left ribbon spool bracket, assembled.

- (17) Remove left ribbon engaging lever (3, fig. 17) spring.
- (18) Loosen left ribbon spool guard bushing screw (34, fig. 17).
- (19) Remove left ribbon spool guard (2, fig. 17) and the two bushings.
- (20) Loosen left ribbon shifting arm lock setscrews (50, fig. 17).
- (21) Remove left ribbon shifting arm lock.
- (22) Remove left ribbon engaging lever shaft, and the collar will drop out. (Right ribbon engaging lever shaft shown in 28, fig. 17).
- (23) Loosen right spool shaft gear (13, fig. 17) setscrew.
- (24) Loosen right spool shaft collar setscrew.
- (25) Loosen right spool shaft bushing setscrew (10, fig. 17).
- (26) Remove right spool shaft (9, fig. 17), and the collar, bushing, gear, spool shaft spring, and shifting arm will drop out.
- (27) Remove right ribbon engaging lever (7, fig. 17) spring.
- (28) Loosen right ribbon spool guard bushing screw (4, fig. 17).
- (29) Remove right ribbon spool guard (8, fig. 17) and the two bushings.
- (30) Loosen right ribbon shifting arm lock setscrew (26, fig. 17).
- (31) Remove right ribbon shifting arm lock (12, fig. 17).
- (32) Remove right ribbon engaging lever (7, fig. 17), and the shaft (28) and collar will drop out.
- (9) Replace ribbon spool shaft collar on bottom of shaft.
- (10) Insert ribbon spool shaft through spool shaft bushing.
- (11) Raise spool shaft slightly and replace ribbon shifting arm and spool shaft spring on ribbon spool shaft.
- (12) Tighten ribbon spool shaft gear setscrew.
- (13) Connect ribbon engaging lever spring.
- (14) Replace detent lever in slot of ribbon bracket.
- (15) Replace detent lever pivot screw.
- (16) Replace detent lever adjusting screw.
- (17) Connect detent lever spring.
- (18) Replace left ribbon engaging lever shaft collar on shaft, with flange upward.
- (19) Insert in bracket the ribbon engaging lever shaft with collar.
- (20) Replace ribbon shifting arm lock on bottom of shaft and tighten screw.
- (21) Replace on bracket the small lower ribbon spool guard bushing.
- (22) Replace ribbon spool guard on bushing.
- (23) Insert large upper ribbon spool guard bushing through guard and lower bushing.
- (24) Hold guard and tighten ribbon spool guard bushing setscrew.
- (25) Replace spool shaft about 1 inch through opening in spool bracket.
- (26) Replace ribbon spool shaft collar on bottom of shaft.
- (27) Push spool shaft through bushing.
- (28) Raise spool shaft slightly and replace ribbon shifting arm and spool shaft spring on ribbon spool shaft.
- (29) Tighten ribbon spool shaft gear setscrew.
- (30) Connect ribbon engaging lever spring.
- (31) Replace ribbon shifting arm disk on feed shaft.
- (32) Replace spring and nut on shaft.
- (33) Replace ribbon feed pawl on feed pawl arm with pin.
- (34) Tighten setscrew.
- (35) Connect feed pawl spring to feed pawl and holding pawl.
- (36) Replace holding pawl and arm on feed shaft.
- (37) Tighten ribbon feed pawl binding screw.

c. Reassembly.

- (1) Replace left ribbon engaging lever shaft collar on shaft, with flange upward.
- (2) Replace ribbon engaging lever shaft.
- (3) Replace ribbon shifting arm lock on bottom of shaft and tighten screw.
- (4) Replace small lower ribbon spool guard bushing on bracket.
- (5) Replace ribbon spool guard on bushing.
- (6) Insert large upper ribbon spool guard bushing through guard and lower bushing.
- (7) Hold guard and tighten ribbon spool guard bushing setscrew.
- (8) Replace spool shaft about 1 inch through opening in spool bracket.

- (38) Replace ribbon feed shaft actuating lever on feed shaft.
- (39) Replace collar on shaft and tighten set-screw.

70. Marginal Stop and Line Lock Mechanism

a. Removal.

- (1) Remove bell rack frame lever (41, fig. 19) screws.
- (2) Remove front small marginal stop rod (13, fig. 19) screws.
- (3) Remove front large marginal stop rod (12, fig. 19) screws.
- (4) Remove marginal stop rod assembly and spring.
- (5) Remove bell rack frame lever (41, fig. 19).
- (6) Remove key lever lock slide link (18, fig. 19) screw.
- (7) Remove link between sublevers and key levers numbers 21 and 22.
- (8) Remove left key lever lock slide stop (23, fig. 19) screw.
- (9) Remove key lever lock slide (25, fig. 19) and spring (22).
- (10) Loosen bell lever hammer (31, fig. 19) set-screw.
- (11) Remove bell lever assembly and pivot stud.
- (12) Remove bell screw (29, fig. 19), bell (37), and nut.

b. Disassembly.

- (1) Loosen left marginal stop rod collar set-screw (1, fig. 19).
- (2) Loosen right marginal stop rod collar set-screw.
- (3) Loosen bell rack frame collar setscrew located at right end of bell rack frame.
- (4) Remove front large (12, fig. 19) and small (13) marginal stop rods, and the marginal stops and collars will drop off.
- (5) Remove right marginal stop knob (27, fig. 19) and pointer.
- (6) Remove right marginal stop handle screw and handle (26, fig. 19).
- (7) Remove right marginal stop lever pivot screw, lever (11, fig. 19), and spring.
- (8) Remove left marginal stop knob and pointer (42, fig. 19).
- (9) Remove left marginal stop handle screw and handle.
- (10) Remove left marginal stop lever pivot screw, lever, and spring.

c. Reassembly.

- (1) Replace left marginal stop spring, lever, and pivot screw on left marginal stop.
- (2) Replace left marginal stop handle and screw.
- (3) Replace left marginal stop pointer and knob.
- (4) Replace right marginal stop spring, lever, and pivot screw on right marginal stop.
- (5) Replace right marginal stop handle and screw.
- (6) Replace right marginal stop pointer and knob.
- (7) Insert front large marginal stop rod through right marginal stop.
- (8) Insert front small marginal stop rod through left and right marginal stops.
- (9) Replace left marginal stop collar and right marginal stop collar.
- (10) Replace bell rack frame upon small rod.
- (11) Replace bell rack frame collar.
- (12) Tighten the three collar setscrews.
- (13) Replace bell rack frame spring on small rod.

71. Tabulator Mechanism

a. Removal.

- (1) Remove four screws in tabulator housing (6, fig. 20).
- (2) Remove housing by pulling up and away from machine.

b. Disassembly.

- (1) Loosen actuating shaft lever setscrews (20, fig. 21).
- (2) Remove actuating shaft lever (9, fig. 21) from shaft.
- (3) Remove actuating shaft screws.
- (4) Remove actuating shaft (22, fig. 21).
- (5) Remove brake arm tension spring adjusting screw (31, fig. 21) and spring.
- (6) Remove brakeshoe arm from actuating plate (3, fig. 21).
- (7) Remove stationary brakeshoe screws and brakeshoes (6, fig. 21).
- (8) Disconnect the three springs in tabulator housing.
- (9) Remove spring anchor plate retainer screw and plate (13, fig. 21).
- (10) Remove stop retainer screw (24, fig. 21) and retainer.
- (11) Remove front tabulator housing top plate from housing.

- (12) Remove rear tabulator housing top plate (21, fig. 21) from housing.
- (13) Remove tabulator stop-clearing plunger (7, fig. 20) from housing.
- (14) Remove tabulator decimal stop (8, fig. 21) from housing.
- (15) Remove tabulator stop-setting plunger screw (15, fig. 20).
- (16) Remove stop-setting plunger (16, fig. 20) from housing.
- (17) Remove stop-setting link lever spring (12, fig. 20).
- (18) Remove stop-setting link lever fulcrum pin (13, fig. 20) and link (10).
- (19) Remove stop-setting rocker lever pivot screw (25, fig. 20).
- (20) Remove tabulator stop-setting link lever (11, fig. 20).
- (21) Remove tabulator key lever stop screws.
- (22) Remove tabulator key lever stop (17, fig. 20) and pad.

c. Reassembly.

- (1) Replace tabulator stop pad on stop.
- (2) Replace key lever stop on housing.
- (3) Replace tabulator stop-setting link lever through tabulator housing.
- (4) Replace stop-setting housing and top plate.
- (5) Replace stop-setting lever rocker screw.
- (6) Replace stop-setting link lever.
- (7) Replace stop-setting link lever spring.
- (8) Replace stop-setting plunger in housing.
- (9) Replace stop-setting plunger screw.
- (10) Replace decimal stop in tabulator housing.
- (11) Replace tabulator stop-clearing plunger in tabulator housing.
- (12) Replace front tabulator housing top plate.
- (13) Replace top plate screws.
- (14) Replace stop retainer and retainer screw.
- (15) Replace spring anchor plate retainer screw and plate.
- (16) Connect stop-setting plunger spring to plunger and anchor plate.
- (17) Connect tabulator decimal stop spring to lever and anchor plate.
- (18) Connect tabulator clear plunger spring to plunger and anchor plate.
- (19) Replace stationary brakeshoe on tabulator housing.
- (20) Replace brakeshoe screws.
- (21) Replace brakeshoe arm on actuating plate.

- (22) Replace brake arm tension adjusting screw and spring.
- (23) Replace actuating plate and actuating shaft.
- (24) Replace actuating shaft screws.
- (25) Replace actuating shaft lever on shaft.
- (26) Tighten shaft lever setscrews.

72. Segment and Type Bar Assembly

a. Removal of Segment.

- (1) Remove fulcrum wire retaining screw (9, fig. 28).
- (2) Remove fulcrum wire retainer plate screw (4, fig. 28).
- (3) Remove fulcrum wire retainer plate (5, fig. 28).
- (4) Remove wire (7, fig. 28) from segment.
- (5) Remove type guide holding screws (11, fig. 28).
- (6) Remove type guide (1, fig. 28).
- (7) Remove segment holding screws (8, fig. 28).
- (8) Remove segment (10, fig. 28).

b. Removal of Type Bars.

- (1) Remove type bars (2, fig. 9) from connecting links.
- (2) Remove connecting links from sublevers (18, fig. 9).
- (3) Remove type bar nest binding screws (13, fig. 18).
- (4) Remove type bar nest (15, fig. 18).

c. Removal of Sublevers.

- (1) Remove sublever fulcrum wire retaining screws, located at left and right ends of sublevers fulcrum wire.
- (2) Remove sublever fulcrum wire, which extends through the end of the sublevers.
- (3) Remove sublever retaining plate screws.
- (4) Remove retaining plate by depressing all key levers and slipping plate free.
- (5) Remove sublevers.

d. Removal of Key Levers and Feature Keys.

- (1) Remove shaft pivot shoulder screw (6, fig. 14).
- (2) Remove backspace link spring (7, fig. 14).
- (3) Work backspace key lever shaft arm assembly out of machine.
- (4) Remove backspace key lever shaft fulcrum bracket (14, fig. 14) screws.
- (5) Remove bracket.

- (6) Loosen spacebar spring adjusting collar lock screw (13, fig. 13) and release all tension on spacebar spring (12, fig. 13).
 - (7) Remove spacebar shaft pivot screws.
 - (8) Remove spacebar, assembled.
 - (9) Remove key lever retaining plate support screw and support, which is located on the bottom at the rear of the typewriter.
 - (10) Remove two key lever retaining plate screws.
 - (11) Remove retaining plate.
 - (12) Remove key set tabulator key levers (12, fig. 21).
 - (13) Remove key lever comb binding screws.
 - (14) Remove key lever comb (19, fig. 19) and key lever stop, which is located in rear of key lever comb.
 - (15) Remove all remaining key levers by depressing rear of key lever and pulling out toward front of machine.
 - (16) Remove all key lever tension springs (16, fig. 9) and screws.
- e. Replacement of Key Levers and Feature Keys.*
- (1) Replace key lever tension adjusting screws.
 - (2) Replace all tension springs in holes of frame.
 - (3) Replace key levers.
 - (4) Replace key lever comb.
 - (5) Replace comb binding screws. Do not tighten.
 - (6) Replace key lever retaining plate and screws.
 - (7) Replace retaining plate support and screw.
 - (8) Replace spacebar, assembled, and pivot screws.
 - (9) Replace backspace key lever shaft fulcrum bracket and screws.
 - (10) Replace backspace key lever and shaft.
 - (11) Replace backspace key lever shaft pivot screw and link spring.
- f. Replacement of Sublevers.*
- (1) Replace sublevers to key lever studs by corresponding numbers, each sublever and key lever being numbered from 1 through 42. Replace fulcrum wire through each sublever as sublever is replaced.
 - (2) Replace fulcrum wire retaining screws.
 - (3) Replace tabulator key lever between sublevers numbers 18 and 19 and numbers 24 and 25.
 - (4) Replace set key lever between sublevers numbers 25 and 26.
 - (5) Replace clear key lever between sublevers numbers 17 and 18.
 - (6) Replace sublever retaining plate and screws.
- g. Replacement of T-type Bars and Segment.*
- (1) Replace type guide on type guide studs.
 - (2) Replace type guide binding screws.
 - (3) Replace segment on segment studs.
 - (4) Replace segment on segment screws.
 - (5) Replace type bar nest on machine frame.
 - (6) Replace type bar nest binding screws.
 - (7) Hook type bars and connecting links numbers 1 through 42 (connecting links numbers 1 through 21 with open face to right, numbers 22 through 42 with open face to left).
 - (8) Depress each key lever numbers 1 through 42, hook connecting links to sublevers, insert type bars in segment, and follow through with segment fulcrum wire.
 - (9) Replace fulcrum wire retaining screw.
 - (10) Replace fulcrum wire retaining plate and screw.

73. Replacement of Units

a. Ribbon Mechanism.

- (1) Replace ribbon feed actuating shaft in slots of frame.
- (2) Replace ribbon feed actuating shaft retainer plates on top of shaft, beveled edge toward shaft.
- (3) Replace shaft retainer plate screws.
- (4) Replace ribbon guide on type guide.
- (5) Replace ribbon guide guard and screws.
- (6) Replace left ribbon bracket, assembled, with bracket holes beneath frame holes.
- (7) Hold bracket and replace bracket screws.
- (8) Replace right ribbon bracket, assembled, with bracket holes beneath frame holes.
- (9) Hold bracket and replace bracket screws.
- (10) Insert ribbon drive shaft through left ribbon bracket about halfway through machine, and replace left drive shaft gear, detent collar, and right drive shaft gear on shaft.
- (11) Push shaft through right ribbon bracket.
- (12) Replace assembled ribbon feed ratchet wheel on right end of shaft.
- (13) Replace ribbon drive shaft extension on right end of shaft.

- (14) Replace ribbon shift lever detent spring, knob, and screw on ribbon shift lever.
 - (15) Replace assembled ribbon shift lever under ribbon bracket and in type bar nest.
 - (16) Replace ribbon shift lever bushing, lift frame bracket, and ribbon shift lever pivot screw.
 - (17) Replace detent pin through type bar nest and through holes in shift lever.
 - (18) Snap detent spring into slot of pin.
 - (19) Replace ribbon spools in ribbon spool guards.
 - (20) Replace ribbon through engaging levers and ribbon guide.
- b. Margin Stop and Line Lock Mechanism.*
- (1) Replace nut, bell, and screw on frame.
 - (2) Replace assembled bell lever hammer and pivot stud to frame.
 - (3) Tighten bell lever hammer pivot stud setscrew.
 - (4) Replace on frame the key lever lock slide with spring.
 - (5) Replace key lever lock slide stop screw, left side.
 - (6) Insert key lever lock slide link through key levers numbers 21 and 22.
 - (7) Replace key lever lock slide link screw.
 - (8) Replace bell rack frame lever through slot of type bar nest.
 - (9) Replace assembled marginal stop rods in frame.
 - (10) Replace small and large marginal stop rod screws on right side.
 - (11) Replace small marginal stop rod screw on left side.
 - (12) Replace large marginal stop rod screw on left side.
 - (13) Replace bell rack frame lever on bell rack frame and replace screws.
- c. Escapement and Backspace Mechanism.*
- (1) Replace escapement frame base and screws on machine frame.
 - (2) Replace tabulator key lever spacer and fulcrum.
 - (3) Fit escapement frame unit on base, rocker arm extension on ribbon feed actuating shaft lever, and universal bar on segment.
 - (4) Hold unit and replace screws.
 - (5) Replace backspace link through key levers numbers 33 and 34.
 - (6) Replace backspace lower link screw and link spring.
- (7) Replace backspace upper link screw and nut.
 - (8) Replace ribbon shift lever link and screws to ribbon shift lever and ribbon shift slide.
- d. Motion and Shift Mechanism.*
- (1) Replace lift frame, assembled.
 - (2) Replace lift frame pivot screws and tighten lock screws.
 - (3) Replace lift frame spring to bracket and lift frame.
 - (4) Hook ribbon guide to actuating lever.
 - (5) Replace ribbon guide actuating lever bracket screws.
 - (6) Replace tabulator lever arm with screw to tabulator lever.
 - (7) Replace assembled lift frame lock, spring, and pivot stud.
 - (8) Tighten pivot stud setscrew.
 - (9) Replace lock release lever shaft and pivot screws.
 - (10) Replace lock release lever shaft spring on lock release lever and lift frame lock.
- e. Main Carriage and Mainspring.*
- (1) Replace mainspring, assembled, to frame.
 - (2) Hold assembled mainspring and replace bracket screws.
 - (3) Replace drawband on drum and drawband anchor stud.
 - (4) Replace wayrod on frame.
 - (5) Replace wayrod bracket screws.
 - (6) Place carriage frame bearing on wayrod, lift front of carriage up, and slide carriage onto wayrod.
 - (7) Slide front scale plate into position.
 - (8) Replace carriage frame stop under right end of frame and replace right front scale plate screw.
 - (9) Replace left front scale plate screw.
- f. Tabulator Mechanism.*
- (1) Replace tabulator housing on frame so that tabulator key levers fit into slots of tabulator housing.
 - (2) Hold housing and replace tabulator housing screws.
 - (3) Disconnect drawband from anchor stud and connect to stud on carriage.
- g. Paper Feed Mechanism.*
- (1) Position lift frame in uppercase position.

- (2) Depress lift hooks and hold.
- (3) Replace subcarriage by placing subcarriage frame bearings in lift hooks so that carriage roll hanger latch is under lift frame rail and on-feet and motion ad-

- justing screws are over and under the motion stop plates.
- (4) Replace carriage controlling links on studs.
- (5) Release shift lock and replace carriage controlling link screws.

Section XX. TROUBLESHOOTING

74. General

The troubleshooting information contained herein is designed to assist the mechanic in determining and eliminating causes of unsatisfactory operation. Troubleshooting consists of observing the trouble, checking possible causes, and correcting the trouble when the cause is found. Since malfunctions are often

due to a combination of conditions, the mechanic must always rely somewhat on his own judgment. If the troubleshooting chart is consulted frequently, it will teach the mechanic to make his own diagnosis correctly and will give him a good fundamental understanding of the effect the various adjustments have on one another.

75. Troubleshooting Chart

a. Main Carriage.

Trouble	Possible Cause	Remedy
(1) Carriage binding or dragging.	Dirt in front scale plate groove. Carriage frame rolls dirty or rusty. Carriage frame rolls too tight. Carriage frame rolls too loose. Front scale plate loose. Carriage frame roll eccentric out of adjustment. Wayrod loose on frame. Wayrod dirty or rusty. Carriage frame bearings binding on wayrod. Carriage frame bearings loose or binding on wayrod. Tabulator brakeband improperly positioned. Brakeband deformed. Mainspring tension insufficient. Carriage frame guide deformed. Mainspring cone spacer missing or broken. Mainspring drum binding.	Clean with emery cloth. Clean with alcohol and emery cloth. Loosen setscrew or pivot screw. Tighten setscrew or pivot screw. Tighten scale plate screws. Adjust eccentric. Position wayrod properly and tighten screws. Clean with emery cloth or alcohol. Check carriage adjustments (par. 14). Tighten screws or check for proper number of ball bearings in roll. Insert brakeband between two brakeshoes. Straighten or replace brakeband. Check mainspring adjustment (pars. 16-18). Form guide away from wayrod. Replace cone spacer. Check mainspring adjustments (par. 16) and make sure spring drum has proper number of ball bearings.
(2) Carriage loose.	Wayrod loose. Carriage frame rolls loose. Front scale plate loose. Carriage frame bearings loose. Carriage frame bearing rolls loose. Clearance between bearings and wayrod excessive. Carriage frame roll eccentric out of adjustment.	Tighten wayrod bracket screws or replace wayrod and brackets if bracket pins are loose in wayrod. Tighten rolls. Tighten front scale plate screws. Tighten carriage frame bearings. Tighten roll screws or replace keeper if it is worn or missing. Check carriage adjustments (par. 14). Adjust eccentric.
(3) Mainspring drum binding.	Drum loose. Spacer missing.	Tighten drum anchor collar screw. Replace spacer.

Trouble	Possible Cause	Remedy
	Ball bearings dirty or rusty. Cover plate binding against drum.	If dirty, clean with alcohol; if rusty, replace ball bearings. Adjust cover plate.

b. Escapement Mechanism.

Trouble	Possible Cause	Remedy
(1) Skipping.	Escapement wheel teeth worn. Escapement rocker loose on pivots. Loose dog spring tension weak or spring disconnected. Pinion pawl not seated in pinion properly. Pinion pawl spring broken. Worn, chipped, or broken tooth in pinion. Worn, chipped, or broken tooth in rack. Rack loose on pivots. Mainspring tension excessive. Loose dog worn or loose. Improper clearance between loose dog and rigid dog. Rigid dog worn. Escapement wheel loose. Main carriage or subcarriage loose. Improper clearance between tabulator actuating shaft lever and tabulator lever arm. Lift frame loose.	Replace escapement wheel. Adjust rocker pivots. Adjust tension or connect spring. Adjust pawl. Replace pawl spring. Replace pinion. Replace rack. Adjust rack. Reduce mainspring tension. Replace or tighten loose dog. Adjust loose dog. Replace rocker. Adjust wheel shaft adjusting nut. Make main carriage or subcarriage adjustments (par. 4). Adjust tabulator actuating shaft lever. Adjust lift frame pivot screws.
(2) Piling and crowding.	Mainspring tension insufficient. Escapement rocker binding. Type bars sticking in segment slots. Backspace pawl and carrier binding against rack.	Adjust mainspring tension. Clean and adjust rocker pivots. Clean segment or straighten type bars. Check backspace adjustments (par. 33).
(3) Choking.	Improper ribbon feed, reverse or cover. Insufficient clearance between dog rocker limit screw and escapement frame when type bar is against segment abutment ring.	Make ribbon adjustments (pars. 34-45). Adjust limit screw for proper clearance of $\frac{1}{64}$ inch.

c. Backspace Mechanism.

Trouble	Possible Cause	Remedy
(1) Overthrowing.	Improper backspace adjustments.	Make backspace adjustments (par. 33).
(2) Underthrowing.	Improper backspace adjustments. Loose or binding main carriage. Pinion and pinion pawl not seated properly. Worn or broken tooth in rack. Rack not seated properly. Mainspring tension excessive.	Make backspace adjustments. Check main carriage adjustments (par. 14). Adjust pinion pawl. Replace rack. Adjust rack. Adjust tension by using tension adjusting knob.

d. Ribbon Mechanism.

Trouble	Possible Cause	Remedy
(1) Improper feed.	<p>Improper installation of spools. Ribbon moving off spools in wrong direction.</p> <p>Ribbon improperly installed in ribbon guide. Cut, torn, or shredded ribbon catching on ribbon guide. Ribbon guide dirty. Ribbon guide deformed. Ribbon spools bent. Spool guard bent. Spool, drive, or feed actuating shaft binding. Spool and drive shaft gears binding. Ratchet wheel worn or bent. Ratchet wheel loose. Feed or holding pawl loose. Feed or holding pawl worn or bent. Ribbon spool brackets loose. Ribbon shift slide binding. Ribbon guide binding.</p>	<p>Install spools properly. See that ribbon moves off spools from front to rear. Install ribbon in ribbon guide. Replace with new ribbon.</p> <p>Clean ribbon guide. Adjust or replace ribbon guide. Adjust or replace ribbon spools. Adjust or replace spool guard. Adjust or replace. Adjust gears. Replace ratchet wheel. Tighten drive shaft extension. Make proper pawl adjustment and tighten. Replace pawl. Tighten spool brackets. Adjust ribbon shift slide. Adjust ribbon guide.</p>
(2) Improper ribbon reverse.	<p>Ribbon engaging lever shaft too tight or too loose. Shifting arm lock not flush in slot of shifting arm, or ribbon engaging lever not flush with guide roll. Improper clearance between disk and shifting arm. Spool shaft spring tension too weak or too strong. Detent arm and detent collar improperly positioned. Mission eyelets in ribbon.</p>	<p>Adjust shifting arm locks. Adjust shifting arm lock. Adjust shifting arm. Form spring for proper tension. Adjust detent collar and arm adjusting screw. Install eyelets 4 inches from end of ribbon. If eyelets are not available, tie knot in ribbon.</p>
(3) Improper ribbon cover.	<p>Lift frame off center, binding, or loose. Universal bar improperly adjusted. Ribbon guide sticking. Cylinder scale frame binding ribbon guide.</p>	<p>Adjust lift frame pivot screws. Adjust universal bar. Clean and adjust ribbon guide. Adjust cylinder scale frame.</p>

e. Margin Stop and Line Lock Mechanism.

Trouble	Possible Cause	Remedy
(1) Banking.	<p>Backlash pawl not stopping escapement wheel. Escapement wheel binding. Pinion wheel and pinion pawls not holding.</p> <p>Rack not meshing properly in pinion wheel. Marginal stop release lever deformed. Marginal stop rod screws too tight. Large marginal stop rod improperly adjusted.</p>	<p>Adjust backlash pawl. Adjust escapement wheel and shaft. Adjust pinion pawl spring or replace pinion and pawls. Adjust carriage rack. Form lever or replace. Loosen marginal stop rod screws. Remove washers on end of rod.</p>
(2) Overthrowing.	<p>Right marginal stop or marginal stop release lever worn. Marginal stop release lever loose.</p>	<p>Replace right marginal stop or marginal stop release lever. Tighten marginal stop release lever pivot screw.</p>

Trouble	Possible Cause	Remedy
(3) Bell ring improper.	Loose bell. Loose bell hammer. Loose bell lever hammer. Bell dirty. Bell hammer too close to bell. Bell hammer resting on bell. Bell lever hammer sticking. Bell rack frame lever too low or too high. Toggle pin not in alinement with bell lever hammer. Bell rack frame loose. Bell rack frame binding. Bell rack frame spring tension improper. Bell trip adjuster worn or broken. Left marginal stop worn.	Tighten bell nut and screw. Solder or replace complete bell lever hammer. Tighten bell lever hammer pivot stud set-screw and position stud. Clean bell. Form bell hammer away from bell. Form bell hammer away from bell. Adjust pivot stud. Adjust bell rack frame lever. Adjust bell rack frame lever. Adjust bell rack frame collar. Adjust bell rack frame collar. Form spring. Replace bell trip adjuster. Replace left marginal stop.
(4) Third line lock improper.	Bell trip adjuster loose. Escapement rocker off center. Escapement wheel binding. Escapement wheel teeth and rigid dog worn. Escapement frame loose.	Tighten screws. Adjust rocker pivot screws. Adjust wheel and shaft. Replace escapement wheel and escapement rocker. Tighten frame screws.
(5) First line lock improper.	Spacebar adjusting lever improperly adjusted. Escapement frame loose. Ribbon feed mechanism out of adjustment.	Adjust spacebar adjusting lever. Tighten frame screws. Make ribbon feed adjustments.

f. Tabulator Mechanism.

Trouble	Possible Cause	Remedy
(1) Stop-setting key not setting tabulator stops.	Deformed key set stop lever. Tabulator stop rack positioned improperly. Clearance between stop-setting link and tabulator stops improper.	Form stop-setting link lever so that it will aline with stop. Adjust rack. Form stop-setting link and adjust height of rack.
(2) Stop-clearing key not clearing stops.	Tabulator stop not in alinement with stop-clearing plunger. Tabulator stop rack too high.	Position tabulator rack to aline stop with plunger. Adjust tabulator stop rack.
(3) Improper tabulation.	Carriage rack not releasing properly from pinion. Carriage moving too slow, brakeband not positioned properly, or brake tension too great. Brake tension too weak. Tabulator decimal stop-clearing tabulator stops.	Adjust actuating shaft lever, tabulator lever arm, tabulator lever, and tabulator lever adjusting screw. Position brakeband properly or decrease brake tension. Increase brake tension. Adjust tabulator stop rack.

g. Motion and Shift Mechanism.

Trouble	Possible Cause	Remedy
Subcarriage not shifting properly; characters too dark, too light, or uneven; type cutting paper.	Carriage controlling links improperly positioned.	Position links properly.

Trouble	Possible Cause	Remedy
	Link screws loose or of improper size. Lift hook shaft improperly adjusted. Lift hook shaft spring tension improperly adjusted. Lift hook shaft supports improperly adjusted. Motion stop plates binding against subcarriage. Line space plunger binding against line space lever tip. Lateral paper guide rod bracket extensions improperly adjusted. Right cylinder knob improperly positioned. Carriage skeleton guide binding subcarriage. Line space ratchet binding on main carriage frame. Cylinder too long, spreading subcarriage. Carriage roll hanger latch and roll improperly adjusted. Lift frame not pivoting properly. Cylinder scale frame binding. Universal bar binding against ribbon shift slide. Shift key levers improperly adjusted to lift frame.	Tighten or replace screws. Adjust lift hook shaft. Adjust lift hook spring tension. Adjust lift hook shaft supports. Loosen plate screw and adjust. Adjust line space lever. Form extensions. Adjust right cylinder knob. Center subcarriage or form guide. Adjust subcarriage and cylinder. Ream cylinder ends. Adjust hanger latch and roll. Adjust lift frame pivot screws. Make cylinder scale frame adjustments. Make universal bar or shift slide adjustment. Form shift key lever stops.

h. Paper Feed Mechanism.

Trouble	Possible Cause	Remedy
(1) Line space overthrowing or underthrowing.	Subcarriage not centered or seated properly. Bent cylinder shaft. Loose cylinder end. Rubber stops worn.	Make subcarriage adjustments. Straighten or replace shaft. Tighten cylinder end screws. Replace rubber stops.
(2) Variable creeping.	Insufficient pressure against drum.	Increase pressure. If drum, bands, or expander levers are worn, replace them.
(3) Variable sticking.	Dirty drums and bands, bent cylinder shaft, or excessive pressure on drum.	Clean drum and bands, decrease pressure against drum, straighten or replace shaft.
(4) Paper slipping.	Cylinder and feed rolls glossy. Feed rolls binding. Flat, cracked, or enlarged feed rolls. Cylinder shield improperly seated. Feed roll tension not uniform.	Clean cylinder and feed rolls with cleaner. Clean feed roll shaft and make feed roll adjustment. Replace rolls. Seat cylinder shield properly. Make feed roll tension adjustments.
(5) Marked carbon copies.	Paper slipping.	Make adjustments in (4) above.

i. Segment and Type Bars.

Trouble	Possible Cause	Remedy
(1) Type bars sticking.	Dirty segment. Dirty sublevers.	Clean segment. Clean sublevers.
(2) Uneven keyboard.	Key lever stop not level.	Position stop so that it will be level.

Section XXI. CLEANING AND LUBRICATION

76. Cleaning

The rust-resistant finish of the Underwood standard typewriter makes it seldom necessary to completely dismantle a machine for cleaning. The general cleaning procedures are as follows:

- a.* Remove cover plates, ribbon, and all rubber parts, because most cleaning fluids swell or decompose rubber.
- b.* Remove all loose dirt by compressed air. Removal of loose dirt shortens the cleaning fluid process and lengthens the life of the fluid.
- c.* Place machine in parts cleaner such as agitene or similar, with solution covering machine. Agitate solution by compressed air for 5 or 10 minutes.
- d.* Remove machine and allow to drain for several minutes.
- e.* Remove excess cleaning fluid with compressed air.
- f.* Lubricate as described in paragraph 77.
- g.* Clean all rubber parts with suitable denatured alcohol or emery cloth.

h. Clean frame and cover plates with soap and water if cleaning fluid does not remove dirt.

77. Lubrication

The Underwood standard typewriter has no fast rotating bearings; therefore, there is no need for continuous lubrication. However, a periodic oiling of all moving parts is necessary. The frequency of lubrication depends upon local conditions. Observe the following instructions:

- a.* Always clean machine before oiling.
- b.* Spray machine with a light-base nongumming oil before replacing rubber parts.
- c.* Allow machine to drain 10 minutes and then wipe off excessive oil.
- d.* Lubricate paper feed roll shafts and paper holder rolls with a lightweight oil.
- e.* Be sure all oil is kept away from ribbon and all points where the oil may spot or stain the paper.

CHAPTER 3

SHIPMENT, LIMITED STORAGE, AND DEMOLITION

TO PREVENT ENEMY USE

78. Shipment and Limited Storage

Prepare Underwood standard typewriters for shipment and limited storage in the following manner:

- a. Clean machine as instructed in paragraph 76.
- b. After cleaning, coat machine with atomized spray of type P-9 preservative.
- c. Remove rubber feet from base of machine, place feet in cotton bag, and tie bag to body of typewriter.
- d. Tie ribbon spools to ribbon spool guards.
- e. Block carriage rails with carriage packing clamps, carriage dowel pins, carriage brace studs, or fixed wedges.
- f. Tie rack release lever down.
- g. Secure carriage in a fixed position by tying or by use of manufacturer's carriage retention clamps if available.
- h. Tie feed roll release lever down.
- i. Place a wad of lint-and-dust-free cellulosic cushioning material in type bar nest to hold type bars in place.
- j. Cover all sharp protruding points on machine with dust-free cellulosic cushioning material and fasten with tape.
- k. Tie one or two cloth bags of silica gel (equivalent of 1 pound) securely to machine in such a manner that machine will not be damaged in transit.
- l. Place standard typewriter cover, supplied with machine, over machine and tie in position.
- m. Wrap machine with grade C moldable paper.

n. Place machine in moistureproof barrier bag.

o. Carefully collapse barrier bag by hand pressure and heat-seal open side to make it airtight and moistureproof.

p. Attach machine encased in barrier bag to a wooden base by running four bolts through base and placing rubber or felt washers at least one-half inch thick on the bolts as shock absorbers. Manufacturer's springs may be used instead of washers. Screw bolts through barrier material into foot-screw mounting points.

q. Screw wooden base, with machine attached, to the crate with $1\frac{3}{4}$ -inch No. 8 flathead wood screws, spaced not less than 3 inches apart on sides.

r. The crate used for packing, constructed of material $\frac{3}{4}$ inch thick and $2\frac{1}{4}$ inches wide, must be $21\frac{1}{2}$ inches long, $18\frac{1}{2}$ inches wide, and 12 inches deep.

79. Demolition To Prevent Enemy Use

On receipt of orders from designated person in authority, destroy typewriters as completely as time, means, and personnel permit. Priority will be given to the obliteration or destruction of all unit identification lettering or markings, all serial numbers, and all manufacturer's nameplates. Smash typewriters and components with a sledge or other heavy instrument; burn with kerosene, gasoline, fuel oil, flame thrower, or incendiary bomb; detonate with firearms, grenades, TNT, or other explosives. In the absence of other means, bury, sink, or scatter parts and components.

APPENDIX

REFERENCES

Pam 310-3	Index of Training Publications.	Pam 310-2	Index of Blank Forms.
Pam 310-4	Index of Technical Manuals, Technical Regulations, Technical Bulletins, Supply Bulletins, Lubrication Orders, and Modification Work Orders.	TB QM 26	Standard Repair Procedures for Office Appliances With Repair Shop Equipment and Tool List.
Pam 310-1	Index of Administrative Publications.	QM 5-51, 52	FSC Group 51, Hand Tools; FSC Group 52, Measuring Tools.

INDEX

	<i>Paragraph</i>	<i>Page</i>		<i>Paragraph</i>	<i>Page</i>
Adjustments:			First line lock:		
Backlash pawl.....	47d(7)	32	Key lever lock slide.....	48d(9)(a)	33
Backspace key lever.....	33a	21	Key lever lock slide link.....	48d(9)(b)	34
Backspace key lever shaft.....	33b	21	Left marginal stop.....	48d(1)	33
Backspace link spring.....	33c	21	Left marginal stop lever handle.....	48d(3)	33
Backspace pawl.....	33d	21	Left marginal stop lever spring.....	48d(2)	33
Backspace pawl carrier spring.....	33e	21	Left marginal stop pointer.....	48d(4)	33
Bell lever hammer and bell hammer.....	48d(8)(b)	33	Left marginal stop rod collar.....	48d(5)	33
Bell rack frame.....	48d(6)	33	Margin release.....	48d(10)	34
Bell rack frame lever and toggle.....	48d(8)(a)	33	Second line lock.....	48d(11)	34
Bell ring.....	48d(8)	33	Third line lock.....	48d(7)	33
Bell trip adjuster.....	48d(8)(c)	33	Lift frame.....	56c(5)	42
Card holders.....	59e	45	Lift frame hooks.....	56a(1)	41
Carriage frame bearings assembly and wayrod.....	14a(2)	5	Lift frame hook spring.....	56a(2)	42
Carriage frame pointer.....	47d(1)	30	Lift frame lock.....	56c(5)	42
Carriage frame rolls and front scale plate.....	14b(2)	5	Lift frame spring.....	56c(2)	42
Carriage frame stop.....	47d(8)	32	Line space adjusting lever.....	18f(2)	9
Carriage rack.....	28b(3)	18	Line space detent.....	18d(2)	9
Carriage roll hanger latch.....	56c(6)	42	Line space drum.....	20c(2)	11
Centering, rocker.....	27a(3)(a)	17	Line space lever.....	18a(2)	8
Centering, universal bar.....	25c(3)	15	Line space pawl.....	18b(2)	8
Cylinder.....	22a(3)	12	Line space plunger.....	18c(2)	9
Cylinder scale frame assembly:			Lock release lever.....	56c(4)	42
Card holders.....	59e	45	Loose dog.....	27b(3)	17
Cylinder scale.....	59d	45	Loose dog stop.....	27c(3)	17
Cylinder scale frame.....	59c	45	Marginal stop release lever.....	47d(3)	30
Scale frame bracket rolls.....	59b	45	Marginal stop rods.....	47d(4)	30
Cylinder shaft knob.....	56a(3)	42	Margin release.....	48d(10)	34
Cylinder shield.....	22c(2)	12	Motion adjustment.....	56c(9)	43
Detent collar.....	41c(3)	26	Motion stop plates.....	56c(7)	42
Drawband.....	16e(2)	8	Normal vertical position, rocker.....	27a(3)(b)	17
Drum.....	16d(2)	8	On-feet adjustment.....	56c(8)	43
Engaging lever shaft.....	42b(3)	27	Paper holder bail.....	22f(2)	13
Escapement wheel.....	28d(3)	18	Paper release mechanism.....	22e(4)	13
First line lock.....	48d(9)	33	Paper table.....	22b(2)	12
Front and rear feed rolls.....	22d(2)	13	Paralleling blade, universal bar.....	25c(4)	15
Front nameplate.....	6b	3	Paralleling cylinder and ring and cylinder adjustment.....	56b	42
Hanger.....	16a(2)	7	Pickup, universal bar.....	25c(5)	16
Key lever lock slide.....	48d(9)(a)	33	Pinion.....	28c(3)	18
Key lever lock slide link.....	48d(9)(b)	34	Ratchet wheel.....	37a(3)	25
Key set tabulator stop-clearing assembly.....	53d	38	Ribbon cover mechanism.....	44	27
Key set tabulator stop-setting assembly.....	50d	34	Ribbon detent lever.....	41d(3)	26
Left marginal stop and line locks assembly:			Ribbon engaging levers.....	42a(3)	27
Bell rack frame.....	48d(6)	33	Ribbon feed actuating shaft.....	35b(3)	23
Bell ring:			Ribbon feed actuating shaft lever.....	35a(3)	23
Bell lever hammer and bell hammer.....	48d(8)(b)	33	Ribbon feed drive shaft.....	37b(3)	25
Bell rack frame lever and toggle.....	48d(8)(a)	33	Ribbon feed drive shaft gears.....	37c(3)	25
Bell trip adjuster.....	48d(8)(c)	33	Ribbon feed pawl assembly.....	36c	25
			Ribbon guide.....	45a(3)	29
			Ribbon guide actuating lever bracket.....	45d(3)	29
			Ribbon guide actuating lever bracket stops.....	45e(3)	29
			Ribbon guide guard.....	45b(3)	29
			Ribbon shifting arms.....	42d(3)	27

	<i>Paragraph</i>	<i>Page</i>		<i>Paragraph</i>	<i>Page</i>
Adjustments—Continued			Backspace link spring.....	33c	21
Ribbon shift lever detent pin spring.....	45c(3)	29	Backspace pawl.....	33d	21
Ribbon shift slide.....	45f(3)	29	Backspace pawl carrier spring.....	33e	21
Ribbon spool guard bushings.....	38c(3)	25	Carriage frame bearings assembly and wayrod.....	14a	5
Ribbon spool guards.....	39a(3)	26	Carriage frame pointer.....	47d(1)	30
Ribbon spools.....	39b(3)	26	Carriage frame rolls and front scale plate.....	14b	5
Ribbon spool shaft gears.....	38a(3)	25	Carriage frame stop.....	47d(8)	32
Ribbon spool shafts.....	38b(3)	25	Carriage rack.....	28b	18
Right marginal stop assembly:			Carriage rack, pinion, and escapement wheel assembly.....	28	18
Backlash pawl.....	47d(7)	32	Centering, rocker.....	27a(3)(a)	17
Carriage frame pointer.....	47d(1)	30	Cleaning.....	76	65
Carriage frame stop.....	47d(8)	32	Cover plates:		
Marginal stop release lever.....	47d(3)	30	Front nameplate.....	6	3
Marginal stop rods.....	47d(4)	30	Left rear cover plate.....	11	5
Right marginal stop lever.....	47d(5)	30	Left side frame cover plate.....	9	4
Right marginal stop lever handle.....	47d(6)	30	Left subcarriage frame end cover plate.....	7	3
Right marginal stop pointer.....	47d(2)	30	Right rear cover plate.....	12	5
Rocker.....	27a(3)	17	Right side frame cover plate.....	10	5
Rocker limit screw.....	27e(3)	17	Right subcarriage frame end cover plate.....	8	4
Second line lock.....	48d(11)	34	Cylinder.....	22a	11
Segment assembly.....	61	46	Cylinder scale.....	67	50
Shift:			Cylinder scale frame assembly:		
Carriage roll hanger latch.....	56c(6)	42	Adjustments.....	59	44
Lift frame.....	56c(1)	42	Function.....	58	44
Lift frame lock.....	56c(5)	42	Cylinder shield.....	22c	12
Lift frame spring.....	56c(2)	42	Demolition to prevent enemy use.....	79	66
Lock release lever.....	56c(4)	42	Description, machine.....	3	3
Motion adjustment.....	56c(9)	43	Detent collar.....	41c	26
Motion stop plates.....	56c(7)	42	Disassembly:		
On-feet adjustment.....	56c(8)	43	Cylinder scale.....	67b	51
Shift key levers.....	56c(3)	42	Escapement and backspace mechanism.....	68b	52
Spacebar mechanism:			Main carriage.....	65b	49
Final check.....	29c(6)	21	Mainspring.....	66b	50
Spacebar.....	29c(3)	20	Marginal stop and line lock mechanism.....	70b	56
Spacebar adjusting lever.....	29c(5)	20	Paper feed mechanism.....	67d	51
Spacebar frame levers.....	29c(4)	20	Ribbon mechanism.....	69b	54
Spacebar shaft.....	29c(1)	19	Tabulator mechanism.....	71b	56
Spacebar spring.....	29c(2)	20	Drawband.....	16e	8
Spring drum shaft.....	16b(2)	7	Drive shaft.....	41b	26
Tabulator assembly.....	52d	37	Drum.....	16d	8
Tabulator stop rack assembly.....	51d	34	Engaging lever shaft.....	42b	27
Tension, universal bar.....	25c(2)	14	Escapement and backspace mechanism:		
Tension-adjusting knob.....	16c(2)	7	Disassembly.....	68b	52
Third line lock.....	48d(7)	33	Reassembly.....	68c	53
Trip adjusting screw.....	27d(3)	17	Removal.....	68a	52
Universal bar:			Replacement.....	73c	59
Centering.....	25c(3)	15	Escapement frame.....	26	16
Paralleling blade.....	25c(4)	15	Escapement rocker assembly:		
Pickup.....	25c(5)	16	Backlash pawl.....	27f	18
Tension.....	25c(2)	14	Loose dog.....	27b	17
Variable line space knob.....	20a(2)	10	Loose dog stop.....	27c	17
Variable pushbutton.....	20b(2)	10	Rocker.....	27a	16
Alinement check.....	63	47	Rocker limit screw.....	27e	17
Alinement methods.....	64	47	Trip adjusting screw.....	27d	17
Automatic reverse.....	42	26	Escapement trip.....	24	13
Backlash pawl.....	27f	18	Escapement wheel.....	28d	18
Backspace key lever.....	33a	21			
Backspace key lever assembly:					
Components.....	31a	21			
Operation.....	31b	21			
Backspace key lever shaft.....	33b	21			

	<i>Paragraph</i>	<i>Page</i>		<i>Paragraph</i>	<i>Page</i>
First line lock.....	48c(1)	32	Orientation.....	2	2
Front and rear feed rolls.....	22d	13	Overthrow, backspace adjustment.....	33g	23
Front nameplate.....	6	3			
Hanger.....	16a	6	Paper feed mechanism:		
Key lever assembly.....	55a	39	Components.....	22	11
Key set tabulator stop-clearing assembly.....	53d	38	Disassembly.....	67d	51
Key set tabulator stop-setting assembly.....	50	34	Reassembly.....	67e	52
			Replacement.....	73g	59
Left marginal stop and line locks assembly:			Paper holder bail.....	22f	13
Adjustments.....	48d	33	Paper release mechanism.....	22e	13
Components.....	48b	32	Paper table.....	22b	12
Operation.....	48c	32	Pinion.....	28c	18
Left rear cover plate.....	11	5	Raising character.....	64b	47
Left side frame cover plate.....	10	5	Ratchet wheel.....	37a	25
Left subcarriage frame end cover plate.....	7	3	Reassembly:		
Lift frame assembly.....	55c	41	Cylinder scale.....	67c	51
Lift frame lock and shift lock assembly.....	55b	39	Escapement and backspace mechanism.....	68c	53
Line space adjusting lever.....	18f	9	Main carriage.....	65c	49
Line space detent.....	18d	9	Mainspring.....	66c	50
Line space detent release lever.....	18e	9	Marginal stop and line lock mechanism.....	70c	56
Line space drum.....	20c	11	Paper feed mechanism.....	67e	52
Line space lever.....	18a	8	Ribbon mechanism.....	69c	55
Line space pawl.....	18b	8	Tabulator mechanism.....	71c	57
Line space plunger.....	18c	8	Ribbon cover mechanism:		
Loose dog.....	27b	17	Ribbon guide.....	45a	27
Loose dog stop.....	27c	17	Ribbon guide actuating lever bracket.....	45d	29
Lowering character.....	64a	47	Ribbon guide actuating lever bracket stops.....	45e	29
Lubrication.....	77	65	Ribbon guide guard.....	45b	29
			Ribbon shift lever detent pin spring.....	45c	29
Main carriage:			Ribbon shift slide.....	45f	29
Components.....	14	5	Ribbon detent lever.....	41d	26
Disassembly.....	65b	49	Ribbon engaging levers.....	42a	27
Reassembly.....	65c	49	Ribbon feed actuating shaft.....	35b	23
Removal.....	65a	49	Ribbon feed actuating shaft assembly.....	35	23
Replacement.....	73e	59	Ribbon feed actuating shaft lever.....	35a	23
Mainspring:			Ribbon feed drive shaft.....	37b	25
Components.....	16	6	Ribbon feed drive shaft assembly.....	37	25
Disassembly.....	66b	50	Ribbon feed drive shaft gears.....	37c	25
Reassembly.....	66c	50	Ribbon feed pawl assembly.....	36	23
Removal.....	66a	50	Ribbon guide.....	45a	27
Replacement.....	73e	59	Ribbon guide actuating lever bracket.....	45d	29
Maintenance and repair tools.....	4	3	Ribbon guide actuating lever bracket stops.....	45e	29
Manual reverse, ribbon:			Ribbon guide guard.....	45b	29
Detent collar.....	41c	26	Ribbon shift lever detent pin spring.....	45c	29
Drive shaft.....	41b	26	Ribbon mechanism:		
Ribbon detent lever.....	41d	26	Disassembly.....	69b	54
Ribbon winding handle.....	41a	26	Reassembly.....	69c	55
Margin mechanism:			Removal.....	69a	54
Left marginal stop and line lock assembly.....	48	32	Replacement.....	73a	58
Right marginal stop assembly.....	47	30	Ribbon shifting arms.....	42d	27
Margin release:			Ribbon spool guard bushings.....	38c	25
Adjustments.....	48d(10)	33	Ribbon spool guards.....	39a	26
Operation.....	48c(2)	32	Ribbon spools.....	39b	26
Margin stop and line locks:			Ribbon spool shafts.....	38b	25
Disassembly.....	70b	56	Ribbon spool shaft gears.....	38a	25
Reassembly.....	70c	56	Ribbon winding handle.....	41a	26
Removal.....	70a	56	Right marginal stop assembly:		
Replacement.....	73b	59	Adjustments.....	47d	30
Marginal stop release lever.....	47d(3)	30	Components.....	47b	30
Marginal stop rods.....	47d(4)	30	Function.....	47a	30
Moving character laterally.....	64c	47	Operation.....	47c	30

	Paragraph	Page		Paragraph	Page
Right marginal stop lever.....	47d(5)	30	Shipment and limited storage.....	78	66
Right marginal stop lever handle.....	47d(6)	30	Spacebar.....	29c(3)	20
Right marginal stop pointer.....	47d(2)	30	Spacebar adjusting lever.....	29c(5)	20
Right rear cover plate.....	12	5	Spacebar frame lever.....	29c(4)	20
Right side frame cover plate.....	10	5	Spacebar mechanism.....	29	19
Right subcarriage frame end cover plate.....	8	4	Spacebar shaft.....	29c(1)	19
Rocker.....	27a	16	Spacebar spring.....	29c(2)	20
Rocker limit screw.....	27e	17	Spool assembly.....	39	26
Scope.....	1	2	Spool shaft assembly.....	38	25
Second line lock.....	48c(3)	32	Spring drum shaft.....	16b	7
Segment assembly.....	60, 61	46	Straightening character.....	64d	47
Segment and type bar assembly:			Subcarriage mechanism.....	54	38
Removal of key levers and feature keys	72d	57	Tabulator assembly.....	52	37
Removal of segment.....	72a	57	Tabulator mechanism.....	71, 73f	56, 59
Removal of sublevers.....	72c	57	Tabulator stop rack assembly.....	51	34
Removal of type bars.....	72b	57	Tension adjusting knob.....	16c	7
Replacement of key levers.....	72e	58	Third line lock.....	48c(4)	33
Replacement of sublevers.....	72f	58	Trip adjusting screw.....	27d	17
Replacement of type bars and segment	72g	58	Troubleshooting chart.....	75	60
Shift mechanism:			Underthrow, backspace adjustment.....	33h	23
Key lever assembly.....	55a	39	Universal bar.....	25	14
Lift frame assembly.....	55c	41	Variable line space knob.....	20a	10
Lift frame lock and shift lock assembly	55b	39	Variable pushbutton.....	20b	10
Shifting arm disks.....	42e	27	Wheel lock, backspace adjustment.....	33f	21
Shifting arm locks.....	42c	27			

[AG 413.51 (9 Aug 55)]

BY ORDER OF THE SECRETARY OF THE ARMY:

MAXWELL D. TAYLOR,
General, United States Army,
Chief of Staff.

OFFICIAL:

JOHN A. KLEIN,
Major General, United States Army,
The Adjutant General.

DISTRIBUTION:

Active Army:

Tec Svc, DA (5) except TQMG (25)
Admin & Tec Svc Bd (2)
Hq, CONARC (2)
OS Maj Comd (10)
OS Base Comd (5)
Log Comd (3)
MDW (5)
Armies (5)
Corps (2)
Div (5)
Ft & Cp (2)
USMA (5)
QM Sch (50)
Gen Depots (5) except Atlanta Gen Depot (None)
QM Sec, Gen Depots (5)

NG: State AG (6); Units—none.

USAR: None.

For explanation of abbreviations used, see SR 320-50-1.

QM Depots (5)

POE (5)

MAAG (2)

Mil Msn (2)

Units organized under following TOE:

10-17R, QM Co, Abn or Inf Div (5)
10-22R, Hq & Hq Det, QM Gp (5)
10-48R, QM Fld Svc Co, Armd QM Bn (5)
10-127R, QM Parts Co (5)
10-237R, QM Rclm & Maint Co, SmbL (5)
10-277R, QM Co, Amph Spt Brig (5)
10-427R, QM Mech and Metal Rep Co (5)
10-500R (AA-AD), QM Svc Org (5)
10-521R, Hq & Hq Co, QM Depot (5)
10-536R, Hq & Hq Det, QM Bn (5)

BOISE PUBLIC LIBRARY



3 1150 00890 6774

TM 10-601 UNDERWOOD TYPEWRITER MAINTENANCE AND REPAIR—1955

